

IEEE 802.11n Digital Standard for R&S[®] Signal Generators Operating Manual



1171.5519.12 – 10

This document describes the following software options:

- R&S®AMU-K54/-K254
1402.9705.02, 1402.9757.02
- R&S®SMATE-K54
1404.7951.02
- R&S®SMBV-K54/-K254
1415.8160.xx, 1415.8354.xx
- R&S®SMJ-K54/-K254
1409.2458.02, 1409.2506.02
- R&S®SMU-K54/-K254
1408.7562.02, 1408.7610.02
- R&S®AFQ-K254
1401.5806.02
- R&S®SFU-K254
2115.2350.02

© 2010 Rohde & Schwarz GmbH & Co. KG

Muehldorfstr. 15, 81671 Munich, Germany

Phone: +49 89 41 29 - 0

Fax: +49 89 41 29 12 164

E-mail: info@rohde-schwarz.com

Internet: <http://www.rohde-schwarz.com>

Subject to change – Data without tolerance limits is not binding.

R&S® is a registered trademark of Rohde & Schwarz GmbH & Co. KG.

Trade names are trademarks of the owners.

The following abbreviations are used throughout this manual: R&S®AMU is abbreviated as R&S AMU, R&S®SMATE is abbreviated as R&S SMATE, R&S®SMBV is abbreviated as R&S SMBV, R&S®SMJ is abbreviated as R&S SMJ, R&S®SMU is abbreviated as R&S SMU, R&S®WinIQSIM2 is abbreviated as R&S WinIQSIM2

Basic Safety Instructions

Always read through and comply with the following safety instructions!

All plants and locations of the Rohde & Schwarz group of companies make every effort to keep the safety standards of our products up to date and to offer our customers the highest possible degree of safety. Our products and the auxiliary equipment they require are designed, built and tested in accordance with the safety standards that apply in each case. Compliance with these standards is continuously monitored by our quality assurance system. The product described here has been designed, built and tested in accordance with the attached EC Certificate of Conformity and has left the manufacturer's plant in a condition fully complying with safety standards. To maintain this condition and to ensure safe operation, you must observe all instructions and warnings provided in this manual. If you have any questions regarding these safety instructions, the Rohde & Schwarz group of companies will be happy to answer them.

Furthermore, it is your responsibility to use the product in an appropriate manner. This product is designed for use solely in industrial and laboratory environments or, if expressly permitted, also in the field and must not be used in any way that may cause personal injury or property damage. You are responsible if the product is used for any intention other than its designated purpose or in disregard of the manufacturer's instructions. The manufacturer shall assume no responsibility for such use of the product.

The product is used for its designated purpose if it is used in accordance with its product documentation and within its performance limits (see data sheet, documentation, the following safety instructions). Using the product requires technical skills and a basic knowledge of English. It is therefore essential that only skilled and specialized staff or thoroughly trained personnel with the required skills be allowed to use the product. If personal safety gear is required for using Rohde & Schwarz products, this will be indicated at the appropriate place in the product documentation. Keep the basic safety instructions and the product documentation in a safe place and pass them on to the subsequent users.

Observing the safety instructions will help prevent personal injury or damage of any kind caused by dangerous situations. Therefore, carefully read through and adhere to the following safety instructions before and when using the product. It is also absolutely essential to observe the additional safety instructions on personal safety, for example, that appear in relevant parts of the product documentation. In these safety instructions, the word "product" refers to all merchandise sold and distributed by the Rohde & Schwarz group of companies, including instruments, systems and all accessories.





Symbols and safety labels

| | | | | | | | |
|---|---|---|---|---|--|---|---|
|  |  |  |  |  |  |  |  |
| Notice, general danger location Observe product documentation | Caution when handling heavy equipment | Danger of electric shock | Warning! Hot surface | PE terminal | Ground | Ground terminal | Be careful when handling electrostatic sensitive devices |

| | | | | | |
|---|---|---|---|--|---|
|  |  |  |  |  |  |
| ON/OFF supply voltage | Standby indication | Direct current (DC) | Alternating current (AC) | Direct/alternating current (DC/AC) | Device fully protected by double (reinforced) insulation |

Tags and their meaning

The following signal words are used in the product documentation in order to warn the reader about risks and dangers.

| | |
|---|---|
|  | indicates a hazardous situation which, if not avoided, will result in death or serious injury. |
|  | indicates a hazardous situation which, if not avoided, could result in death or serious injury. |
|  | indicates a hazardous situation which, if not avoided, could result in minor or moderate injury. |
|  | indicates the possibility of incorrect operation which can result in damage to the product. In the product documentation, the word ATTENTION is used synonymously. |

These tags are in accordance with the standard definition for civil applications in the European Economic Area. Definitions that deviate from the standard definition may also exist in other economic areas or military applications. It is therefore essential to make sure that the tags described here are always used only in connection with the related product documentation and the related product. The use of tags in connection with unrelated products or documentation can result in misinterpretation and in personal injury or material damage.

Operating states and operating positions

The product may be operated only under the operating conditions and in the positions specified by the manufacturer, without the product's ventilation being obstructed. If the manufacturer's specifications are not observed, this can result in electric shock, fire and/or serious personal injury or death. Applicable local or national safety regulations and rules for the prevention of accidents must be observed in all work performed.

1. Unless otherwise specified, the following requirements apply to Rohde & Schwarz products: predefined operating position is always with the housing floor facing down, IP protection 2X, pollution severity 2, overvoltage category 2, use only indoors, max. operating altitude 2000 m above sea level, max. transport altitude 4500 m above sea level. A tolerance of $\pm 10\%$ shall apply to the nominal voltage and $\pm 5\%$ to the nominal frequency.
2. Do not place the product on surfaces, vehicles, cabinets or tables that for reasons of weight or stability are unsuitable for this purpose. Always follow the manufacturer's installation instructions when installing the product and fastening it to objects or structures (e.g. walls and shelves). An installation that is not carried out as described in the product documentation could result in personal injury or death.
3. Do not place the product on heat-generating devices such as radiators or fan heaters. The ambient temperature must not exceed the maximum temperature specified in the product documentation or in the data sheet. Product overheating can cause electric shock, fire and/or serious personal injury or death.

Electrical safety

If the information on electrical safety is not observed either at all to the extent necessary, electric shock, fire and/or serious personal injury or death may occur.

1. Prior to switching on the product, always ensure that the nominal voltage setting on the product matches the nominal voltage of the AC supply network. If a different voltage is to be set, the power fuse of the product may have to be changed accordingly.
2. In the case of products of safety class I with movable power cord and connector, operation is permitted only on sockets with an earthing contact and protective earth connection.
3. Intentionally breaking the protective earth connection either in the feed line or in the product itself is not permitted. Doing so can result in the danger of an electric shock from the product. If extension cords or connector strips are implemented, they must be checked on a regular basis to ensure that they are safe to use.
4. If the product does not have a power switch for disconnection from the AC supply network, the plug of the connecting cable is regarded as the disconnecting device. In such cases, always ensure that the power plug is easily reachable and accessible at all times (corresponding to the length of connecting cable, approx. 2 m). Functional or electronic switches are not suitable for providing disconnection from the AC supply network. If products without power switches are integrated into racks or systems, a disconnecting device must be provided at the system level.
5. Never use the product if the power cable is damaged. Check the power cable on a regular basis to ensure that it is in proper operating condition. By taking appropriate safety measures and carefully laying the power cable, you can ensure that the cable will not be damaged and that no one can be hurt by, for example, tripping over the cable or suffering an electric shock.
6. The product may be operated only from TN/TT supply networks fused with max. 16 A (higher fuse only after consulting with the Rohde & Schwarz group of companies).
7. Do not insert the plug into sockets that are dusty or dirty. Insert the plug firmly and all the way into the socket. Otherwise, sparks that result in fire and/or injuries may occur.
8. Do not overload any sockets, extension cords or connector strips; doing so can cause fire or electric shocks.
9. For measurements in circuits with voltages $V_{\text{rms}} > 30 \text{ V}$, suitable measures (e.g. appropriate measuring equipment, fusing, current limiting, electrical separation, insulation) should be taken to avoid any hazards.
10. Ensure that the connections with information technology equipment, e.g. PCs or other industrial computers, comply with the IEC60950-1/EN60950-1 or IEC61010-1/EN 61010-1 standards that apply in each case.
11. Unless expressly permitted, never remove the cover or any part of the housing while the product is in operation. Doing so will expose circuits and components and can lead to injuries, fire or damage to the product.
12. If a product is to be permanently installed, the connection between the PE terminal on site and the product's PE conductor must be made first before any other connection is made. The product may be installed and connected only by a licensed electrician.
13. For permanently installed equipment without built-in fuses, circuit breakers or similar protective devices, the supply circuit must be fused in such a way that anyone who has access to the product, as well as the product itself, is adequately protected from injury or damage.

Basic Safety Instructions

14. Use suitable overvoltage protection to ensure that no overvoltage (such as that caused by a bolt of lightning) can reach the product. Otherwise, the person operating the product will be exposed to the danger of an electric shock.
15. Any object that is not designed to be placed in the openings of the housing must not be used for this purpose. Doing so can cause short circuits inside the product and/or electric shocks, fire or injuries.
16. Unless specified otherwise, products are not liquid-proof (see also section "Operating states and operating positions", item 1. Therefore, the equipment must be protected against penetration by liquids. If the necessary precautions are not taken, the user may suffer electric shock or the product itself may be damaged, which can also lead to personal injury.
17. Never use the product under conditions in which condensation has formed or can form in or on the product, e.g. if the product has been moved from a cold to a warm environment. Penetration by water increases the risk of electric shock.
18. Prior to cleaning the product, disconnect it completely from the power supply (e.g. AC supply network or battery). Use a soft, non-linting cloth to clean the product. Never use chemical cleaning agents such as alcohol, acetone or diluents for cellulose lacquers.

Operation

1. Operating the products requires special training and intense concentration. Make sure that persons who use the products are physically, mentally and emotionally fit enough to do so; otherwise, injuries or material damage may occur. It is the responsibility of the employer/operator to select suitable personnel for operating the products.
2. Before you move or transport the product, read and observe the section titled "Transport".
3. As with all industrially manufactured goods, the use of substances that induce an allergic reaction (allergens) such as nickel cannot be generally excluded. If you develop an allergic reaction (such as a skin rash, frequent sneezing, red eyes or respiratory difficulties) when using a Rohde & Schwarz product, consult a physician immediately to determine the cause and to prevent health problems or stress.
4. Before you start processing the product mechanically and/or thermally, or before you take it apart, be sure to read and pay special attention to the section titled "Waste disposal", item 1.
5. Depending on the function, certain products such as RF radio equipment can produce an elevated level of electromagnetic radiation. Considering that unborn babies require increased protection, pregnant women must be protected by appropriate measures. Persons with pacemakers may also be exposed to risks from electromagnetic radiation. The employer/operator must evaluate workplaces where there is a special risk of exposure to radiation and, if necessary, take measures to avert the potential danger.
6. Should a fire occur, the product may release hazardous substances (gases, fluids, etc.) that can cause health problems. Therefore, suitable measures must be taken, e.g. protective masks and protective clothing must be worn.
7. If a laser product (e.g. a CD/DVD drive) is integrated into a Rohde & Schwarz product, absolutely no other settings or functions may be used as described in the product documentation. The objective is to prevent personal injury (e.g. due to laser beams).

Repair and service

1. The product may be opened only by authorized, specially trained personnel. Before any work is performed on the product or before the product is opened, it must be disconnected from the AC supply network. Otherwise, personnel will be exposed to the risk of an electric shock.
2. Adjustments, replacement of parts, maintenance and repair may be performed only by electrical experts authorized by Rohde & Schwarz. Only original parts may be used for replacing parts relevant to safety (e.g. power switches, power transformers, fuses). A safety test must always be performed after parts relevant to safety have been replaced (visual inspection, PE conductor test, insulation resistance measurement, leakage current measurement, functional test). This helps ensure the continued safety of the product.

Batteries and rechargeable batteries/cells

If the information regarding batteries and rechargeable batteries/cells is not observed either at all or to the extent necessary, product users may be exposed to the risk of explosions, fire and/or serious personal injury, and, in some cases, death. Batteries and rechargeable batteries with alkaline electrolytes (e.g. lithium cells) must be handled in accordance with the EN 62133 standard.

1. Cells must not be taken apart or crushed.
2. Cells or batteries must not be exposed to heat or fire. Storage in direct sunlight must be avoided. Keep cells and batteries clean and dry. Clean soiled connectors using a dry, clean cloth.
3. Cells or batteries must not be short-circuited. Cells or batteries must not be stored in a box or in a drawer where they can short-circuit each other, or where they can be short-circuited by other conductive materials. Cells and batteries must not be removed from their original packaging until they are ready to be used.
4. Keep cells and batteries out of the hands of children. If a cell or a battery has been swallowed, seek medical aid immediately.
5. Cells and batteries must not be exposed to any mechanical shocks that are stronger than permitted.
6. If a cell develops a leak, the fluid must not be allowed to come into contact with the skin or eyes. If contact occurs, wash the affected area with plenty of water and seek medical aid.
7. Improperly replacing or charging cells or batteries that contain alkaline electrolytes (e.g. lithium cells) can cause explosions. Replace cells or batteries only with the matching Rohde & Schwarz type (see parts list) in order to ensure the safety of the product.
8. Cells and batteries must be recycled and kept separate from residual waste. Rechargeable batteries and normal batteries that contain lead, mercury or cadmium are hazardous waste. Observe the national regulations regarding waste disposal and recycling.

Transport

1. The product may be very heavy. Therefore, the product must be handled with care. In some cases, the user may require a suitable means of lifting or moving the product (e.g. with a lift-truck) to avoid back or other physical injuries.

2. Handles on the products are designed exclusively to enable personnel to transport the product. It is therefore not permissible to use handles to fasten the product to or on transport equipment such as cranes, fork lifts, wagons, etc. The user is responsible for securely fastening the products to or on the means of transport or lifting. Observe the safety regulations of the manufacturer of the means of transport or lifting. Noncompliance can result in personal injury or material damage.
3. If you use the product in a vehicle, it is the sole responsibility of the driver to drive the vehicle safely and properly. The manufacturer assumes no responsibility for accidents or collisions. Never use the product in a moving vehicle if doing so could distract the driver of the vehicle. Adequately secure the product in the vehicle to prevent injuries or other damage in the event of an accident.

Waste disposal

1. If products or their components are mechanically and/or thermally processed in a manner that goes beyond their intended use, hazardous substances (heavy-metal dust such as lead, beryllium, nickel) may be released. For this reason, the product may only be disassembled by specially trained personnel. Improper disassembly may be hazardous to your health. National waste disposal regulations must be observed.
2. If handling the product releases hazardous substances or fuels that must be disposed of in a special way, e.g. coolants or engine oils that must be replenished regularly, the safety instructions of the manufacturer of the hazardous substances or fuels and the applicable regional waste disposal regulations must be observed. Also observe the relevant safety instructions in the product documentation. The improper disposal of hazardous substances or fuels can cause health problems and lead to environmental damage.

Informaciones elementales de seguridad

Es imprescindible leer y observar las siguientes instrucciones e informaciones de seguridad!

El principio del grupo de empresas Rohde & Schwarz consiste en tener nuestros productos siempre al día con los estándares de seguridad y de ofrecer a nuestros clientes el máximo grado de seguridad. Nuestros productos y todos los equipos adicionales son siempre fabricados y examinados según las normas de seguridad vigentes. Nuestro sistema de garantía de calidad controla constantemente que sean cumplidas estas normas. El presente producto ha sido fabricado y examinado según el certificado de conformidad adjunto de la UE y ha salido de nuestra planta en estado impecable según los estándares técnicos de seguridad. Para poder preservar este estado y garantizar un funcionamiento libre de peligros, el usuario deberá atenerse a todas las indicaciones, informaciones de seguridad y notas de alerta. El grupo de empresas Rohde & Schwarz está siempre a su disposición en caso de que tengan preguntas referentes a estas informaciones de seguridad.

Además queda en la responsabilidad del usuario utilizar el producto en la forma debida. Este producto está destinado exclusivamente al uso en la industria y el laboratorio o, si ha sido expresamente autorizado, para aplicaciones de campo y de ninguna manera deberá ser utilizado de modo que alguna persona/cosa pueda sufrir daño. El uso del producto fuera de sus fines definidos o sin tener en cuenta las instrucciones del fabricante queda en la responsabilidad del usuario. El fabricante no se hace en ninguna forma responsable de consecuencias a causa del mal uso del producto.

Informaciones elementales de seguridad

Se parte del uso correcto del producto para los fines definidos si el producto es utilizado conforme a las indicaciones de la correspondiente documentación del producto y dentro del margen de rendimiento definido (ver hoja de datos, documentación, informaciones de seguridad que siguen). El uso del producto hace necesarios conocimientos técnicos y ciertos conocimientos del idioma inglés. Por eso se debe tener en cuenta que el producto solo pueda ser operado por personal especializado o personas instruidas en profundidad con las capacidades correspondientes. Si fuera necesaria indumentaria de seguridad para el uso de productos de Rohde & Schwarz, encontraría la información debida en la documentación del producto en el capítulo correspondiente. Guarde bien las informaciones de seguridad elementales, así como la documentación del producto, y entréguelas a usuarios posteriores.

Tener en cuenta las informaciones de seguridad sirve para evitar en lo posible lesiones o daños por peligros de toda clase. Por eso es imprescindible leer detalladamente y comprender por completo las siguientes informaciones de seguridad antes de usar el producto, y respetarlas durante el uso del producto. Deberán tenerse en cuenta todas las demás informaciones de seguridad, como p. ej. las referentes a la protección de personas, que encontrarán en el capítulo correspondiente de la documentación del producto y que también son de obligado cumplimiento. En las presentes informaciones de seguridad se recogen todos los objetos que distribuye el grupo de empresas Rohde & Schwarz bajo la denominación de "producto", entre ellos también aparatos, instalaciones así como toda clase de accesorios.

Símbolos y definiciones de seguridad

| | | | | | | | |
|---|---|---|---|---|--|---|---|
|  |  |  |  |  |  |  |  |
| Aviso: punto de peligro general Observar la documentación del producto | Atención en el manejo de dispositivos de peso elevado | Peligro de choque eléctrico | Advertencia: superficie caliente | Conexión a conductor de protección | Conexión a tierra | Conexión a masa | Aviso: Cuidado en el manejo de dispositivos sensibles a la electrostática (ESD) |

| | | | | | |
|---|---|---|---|--|---|
|  |  |  |  |  |  |
| Tensión de alimentación de PUESTA EN MARCHA / PARADA | Indicación de estado de espera (Standby) | Corriente continua (DC) | Corriente alterna (AC) | Corriente continua / Corriente alterna (DC/AC) | El aparato está protegido en su totalidad por un aislamiento doble (reforzado) |

Palabras de señal y su significado

En la documentación del producto se utilizan las siguientes palabras de señal con el fin de advertir contra riesgos y peligros.



PELIGRO identifica un peligro inminente con riesgo elevado que provocará muerte o lesiones graves si no se evita.



ADVERTENCIA identifica un posible peligro con riesgo medio de provocar muerte o lesiones (graves) si no se evita.



ATENCIÓN identifica un peligro con riesgo reducido de provocar lesiones leves o moderadas si no se evita.



AVISO indica la posibilidad de utilizar mal el producto y, como consecuencia, dañarlo.

En la documentación del producto se emplea de forma sinónima el término CUIDADO.

Las palabras de señal corresponden a la definición habitual para aplicaciones civiles en el área económica europea. Pueden existir definiciones diferentes a esta definición en otras áreas económicas o en aplicaciones militares. Por eso se deberá tener en cuenta que las palabras de señal aquí descritas sean utilizadas siempre solamente en combinación con la correspondiente documentación del producto y solamente en combinación con el producto correspondiente. La utilización de las palabras de señal en combinación con productos o documentaciones que no les correspondan puede llevar a interpretaciones equivocadas y tener por consecuencia daños en personas u objetos.

Estados operativos y posiciones de funcionamiento

El producto solamente debe ser utilizado según lo indicado por el fabricante respecto a los estados operativos y posiciones de funcionamiento sin que se obstruya la ventilación. Si no se siguen las indicaciones del fabricante, pueden producirse choques eléctricos, incendios y/o lesiones graves con posible consecuencia de muerte. En todos los trabajos deberán ser tenidas en cuenta las normas nacionales y locales de seguridad del trabajo y de prevención de accidentes.

1. Si no se convino de otra manera, es para los productos Rohde & Schwarz válido lo que sigue: como posición de funcionamiento se define por principio la posición con el suelo de la caja para abajo, modo de protección IP 2X, grado de suciedad 2, categoría de sobrecarga eléctrica 2, uso solamente en estancias interiores, utilización hasta 2000 m sobre el nivel del mar, transporte hasta 4500 m sobre el nivel del mar. Se aplicará una tolerancia de $\pm 10\%$ sobre el voltaje nominal y de $\pm 5\%$ sobre la frecuencia nominal.
2. No sitúe el producto encima de superficies, vehículos, estantes o mesas, que por sus características de peso o de estabilidad no sean aptos para él. Siga siempre las instrucciones de instalación del fabricante cuando instale y asegure el producto en objetos o estructuras (p. ej. paredes y estantes). Si se realiza la instalación de modo distinto al indicado en la documentación del producto, pueden causarse lesiones o incluso la muerte.
3. No ponga el producto sobre aparatos que generen calor (p. ej. radiadores o calefactores). La temperatura ambiente no debe superar la temperatura máxima especificada en la documentación del producto o en la hoja de datos. En caso de sobrecalentamiento del producto, pueden producirse choques eléctricos, incendios y/o lesiones graves con posible consecuencia de muerte.

Seguridad eléctrica

Si no se siguen (o se siguen de modo insuficiente) las indicaciones del fabricante en cuanto a seguridad eléctrica, pueden producirse choques eléctricos, incendios y/o lesiones graves con posible consecuencia de muerte.

1. Antes de la puesta en marcha del producto se deberá comprobar siempre que la tensión preseleccionada en el producto coincida con la de la red de alimentación eléctrica. Si es necesario modificar el ajuste de tensión, también se deberán cambiar en caso dado los fusibles correspondientes del producto.
2. Los productos de la clase de protección I con alimentación móvil y enchufe individual solamente podrán enchufarse a tomas de corriente con contacto de seguridad y con conductor de protección conectado.
3. Queda prohibida la interrupción intencionada del conductor de protección, tanto en la toma de corriente como en el mismo producto. La interrupción puede tener como consecuencia el riesgo de que el producto sea fuente de choques eléctricos. Si se utilizan cables alargadores o regletas de enchufe, deberá garantizarse la realización de un examen regular de los mismos en cuanto a su estado técnico de seguridad.
4. Si el producto no está equipado con un interruptor para desconectarlo de la red, se deberá considerar el enchufe del cable de conexión como interruptor. En estos casos se deberá asegurar que el enchufe siempre sea de fácil acceso (de acuerdo con la longitud del cable de conexión, aproximadamente 2 m). Los interruptores de función o electrónicos no son aptos para el corte de la red eléctrica. Si los productos sin interruptor están integrados en bastidores o instalaciones, se deberá colocar el interruptor en el nivel de la instalación.
5. No utilice nunca el producto si está dañado el cable de conexión a red. Compruebe regularmente el correcto estado de los cables de conexión a red. Asegúrese, mediante las medidas de protección y de instalación adecuadas, de que el cable de conexión a red no pueda ser dañado o de que nadie pueda ser dañado por él, p. ej. al tropezar o por un choque eléctrico.
6. Solamente está permitido el funcionamiento en redes de alimentación TN/TT aseguradas con fusibles de 16 A como máximo (utilización de fusibles de mayor amperaje solo previa consulta con el grupo de empresas Rohde & Schwarz).
7. Nunca conecte el enchufe en tomas de corriente sucias o llenas de polvo. Introduzca el enchufe por completo y fuertemente en la toma de corriente. La no observación de estas medidas puede provocar chispas, fuego y/o lesiones.
8. No sobrecargue las tomas de corriente, los cables alargadores o las regletas de enchufe ya que esto podría causar fuego o choques eléctricos.
9. En las mediciones en circuitos de corriente con una tensión $U_{\text{eff}} > 30 \text{ V}$ se deberán tomar las medidas apropiadas para impedir cualquier peligro (p. ej. medios de medición adecuados, seguros, limitación de tensión, corte protector, aislamiento etc.).
10. Para la conexión con dispositivos informáticos como un PC o un ordenador industrial, debe comprobarse que éstos cumplan los estándares IEC60950-1/EN60950-1 o IEC61010-1/EN 61010-1 válidos en cada caso.
11. A menos que esté permitido expresamente, no retire nunca la tapa ni componentes de la carcasa mientras el producto esté en servicio. Esto pone a descubierto los cables y componentes eléctricos y puede causar lesiones, fuego o daños en el producto.

12. Si un producto se instala en un lugar fijo, se deberá primero conectar el conductor de protección fijo con el conductor de protección del producto antes de hacer cualquier otra conexión. La instalación y la conexión deberán ser efectuadas por un electricista especializado.
13. En el caso de dispositivos fijos que no estén provistos de fusibles, interruptor automático ni otros mecanismos de seguridad similares, el circuito de alimentación debe estar protegido de modo que todas las personas que puedan acceder al producto, así como el producto mismo, estén a salvo de posibles daños.
14. Todo producto debe estar protegido contra sobretensión (debida p. ej. a una caída del rayo) mediante los correspondientes sistemas de protección. Si no, el personal que lo utilice quedará expuesto al peligro de choque eléctrico.
15. No debe introducirse en los orificios de la caja del aparato ningún objeto que no esté destinado a ello. Esto puede producir cortocircuitos en el producto y/o puede causar choques eléctricos, fuego o lesiones.
16. Salvo indicación contraria, los productos no están impermeabilizados (ver también el capítulo "Estados operativos y posiciones de funcionamiento", punto 1). Por eso es necesario tomar las medidas necesarias para evitar la entrada de líquidos. En caso contrario, existe peligro de choque eléctrico para el usuario o de daños en el producto, que también pueden redundar en peligro para las personas.
17. No utilice el producto en condiciones en las que pueda producirse o ya se hayan producido condensaciones sobre el producto o en el interior de éste, como p. ej. al desplazarlo de un lugar frío a otro caliente. La entrada de agua aumenta el riesgo de choque eléctrico.
18. Antes de la limpieza, desconecte por completo el producto de la alimentación de tensión (p. ej. red de alimentación o batería). Realice la limpieza de los aparatos con un paño suave, que no se deshilache. No utilice bajo ningún concepto productos de limpieza químicos como alcohol, acetona o diluyentes para lacas nitrocelulósicas.

Funcionamiento

1. El uso del producto requiere instrucciones especiales y una alta concentración durante el manejo. Debe asegurarse que las personas que manejen el producto estén a la altura de los requerimientos necesarios en cuanto a aptitudes físicas, psíquicas y emocionales, ya que de otra manera no se pueden excluir lesiones o daños de objetos. El empresario u operador es responsable de seleccionar el personal usuario apto para el manejo del producto.
2. Antes de desplazar o transportar el producto, lea y tenga en cuenta el capítulo "Transporte".
3. Como con todo producto de fabricación industrial no puede quedar excluida en general la posibilidad de que se produzcan alergias provocadas por algunos materiales empleados, los llamados alérgenos (p. ej. el níquel). Si durante el manejo de productos Rohde & Schwarz se producen reacciones alérgicas, como p. ej. irritaciones cutáneas, estornudos continuos, enrojecimiento de la conjuntiva o dificultades respiratorias, debe avisarse inmediatamente a un médico para investigar las causas y evitar cualquier molestia o daño a la salud.
4. Antes de la manipulación mecánica y/o térmica o el desmontaje del producto, debe tenerse en cuenta imprescindiblemente el capítulo "Eliminación", punto 1.

5. Ciertos productos, como p. ej. las instalaciones de radiocomunicación RF, pueden a causa de su función natural, emitir una radiación electromagnética aumentada. Deben tomarse todas las medidas necesarias para la protección de las mujeres embarazadas. También las personas con marcapasos pueden correr peligro a causa de la radiación electromagnética. El empresario/operador tiene la obligación de evaluar y señalar las áreas de trabajo en las que exista un riesgo elevado de exposición a radiaciones.
6. Tenga en cuenta que en caso de incendio pueden desprenderse del producto sustancias tóxicas (gases, líquidos etc.) que pueden generar daños a la salud. Por eso, en caso de incendio deben usarse medidas adecuadas, como p. ej. máscaras antigás e indumentaria de protección.
7. En caso de que un producto Rohde & Schwarz contenga un producto láser (p. ej. un lector de CD/DVD), no debe usarse ninguna otra configuración o función aparte de las descritas en la documentación del producto, a fin de evitar lesiones (p. ej. debidas a irradiación láser).

Reparación y mantenimiento

1. El producto solamente debe ser abierto por personal especializado con autorización para ello. Antes de manipular el producto o abrirlo, es obligatorio desconectarlo de la tensión de alimentación, para evitar toda posibilidad de choque eléctrico.
2. El ajuste, el cambio de partes, el mantenimiento y la reparación deberán ser efectuadas solamente por electricistas autorizados por Rohde & Schwarz. Si se reponen partes con importancia para los aspectos de seguridad (p. ej. el enchufe, los transformadores o los fusibles), solamente podrán ser sustituidos por partes originales. Después de cada cambio de partes relevantes para la seguridad deberá realizarse un control de seguridad (control a primera vista, control del conductor de protección, medición de resistencia de aislamiento, medición de la corriente de fuga, control de funcionamiento). Con esto queda garantizada la seguridad del producto.

Baterías y acumuladores o celdas

Si no se siguen (o se siguen de modo insuficiente) las indicaciones en cuanto a las baterías y acumuladores o celdas, pueden producirse explosiones, incendios y/o lesiones graves con posible consecuencia de muerte. El manejo de baterías y acumuladores con electrolitos alcalinos (p. ej. celdas de litio) debe seguir el estándar EN 62133.

1. No deben desmontarse, abrirse ni triturarse las celdas.
2. Las celdas o baterías no deben someterse a calor ni fuego. Debe evitarse el almacenamiento a la luz directa del sol. Las celdas y baterías deben mantenerse limpias y secas. Limpiar las conexiones sucias con un paño seco y limpio.
3. Las celdas o baterías no deben cortocircuitarse. Es peligroso almacenar las celdas o baterías en estuches o cajones en cuyo interior puedan cortocircuitarse por contacto recíproco o por contacto con otros materiales conductores. No deben extraerse las celdas o baterías de sus embalajes originales hasta el momento en que vayan a utilizarse.
4. Mantener baterías y celdas fuera del alcance de los niños. En caso de ingestión de una celda o batería, avisar inmediatamente a un médico.
5. Las celdas o baterías no deben someterse a impactos mecánicos fuertes indebidos.

6. En caso de falta de estanqueidad de una celda, el líquido vertido no debe entrar en contacto con la piel ni los ojos. Si se produce contacto, lavar con agua abundante la zona afectada y avisar a un médico.
7. En caso de cambio o recarga inadecuados, las celdas o baterías que contienen electrolitos alcalinos (p. ej. las celdas de litio) pueden explotar. Para garantizar la seguridad del producto, las celdas o baterías solo deben ser sustituidas por el tipo Rohde & Schwarz correspondiente (ver lista de recambios).
8. Las baterías y celdas deben reciclarse y no deben tirarse a la basura doméstica. Las baterías o acumuladores que contienen plomo, mercurio o cadmio deben tratarse como residuos especiales. Respete en esta relación las normas nacionales de eliminación y reciclaje.

Transporte

1. El producto puede tener un peso elevado. Por eso es necesario desplazarlo o transportarlo con precaución y, si es necesario, usando un sistema de elevación adecuado (p. ej. una carretilla elevadora), a fin de evitar lesiones en la espalda u otros daños personales.
2. Las asas instaladas en los productos sirven solamente de ayuda para el transporte del producto por personas. Por eso no está permitido utilizar las asas para la sujeción en o sobre medios de transporte como p. ej. grúas, carretillas elevadoras de horquilla, carros etc. Es responsabilidad suya fijar los productos de manera segura a los medios de transporte o elevación. Para evitar daños personales o daños en el producto, siga las instrucciones de seguridad del fabricante del medio de transporte o elevación utilizado.
3. Si se utiliza el producto dentro de un vehículo, recae de manera exclusiva en el conductor la responsabilidad de conducir el vehículo de manera segura y adecuada. El fabricante no asumirá ninguna responsabilidad por accidentes o colisiones. No utilice nunca el producto dentro de un vehículo en movimiento si esto pudiera distraer al conductor. Asegure el producto dentro del vehículo debidamente para evitar, en caso de un accidente, lesiones u otra clase de daños.

Eliminación

1. Si se trabaja de manera mecánica y/o térmica cualquier producto o componente más allá del funcionamiento previsto, pueden liberarse sustancias peligrosas (polvos con contenido de metales pesados como p. ej. plomo, berilio o níquel). Por eso el producto solo debe ser desmontado por personal especializado con formación adecuada. Un desmontaje inadecuado puede ocasionar daños para la salud. Se deben tener en cuenta las directivas nacionales referentes a la eliminación de residuos.
2. En caso de que durante el trato del producto se formen sustancias peligrosas o combustibles que deban tratarse como residuos especiales (p. ej. refrigerantes o aceites de motor con intervalos de cambio definidos), deben tenerse en cuenta las indicaciones de seguridad del fabricante de dichas sustancias y las normas regionales de eliminación de residuos. Tenga en cuenta también en caso necesario las indicaciones de seguridad especiales contenidas en la documentación del producto. La eliminación incorrecta de sustancias peligrosas o combustibles puede causar daños a la salud o daños al medio ambiente.

Contents

| | | |
|----------|--|-----------|
| 1 | Preface | 5 |
| 1.1 | Documentation Overview..... | 5 |
| 1.2 | Typographical Conventions..... | 6 |
| 2 | IEEE 802.11n WLAN-N Signal Generation | 7 |
| 2.1 | Signal Overview..... | 7 |
| 2.1.1 | Operation Modes..... | 7 |
| 2.1.2 | Signal Generation..... | 8 |
| 2.2 | Typical Workflows..... | 9 |
| 2.2.1 | Generating a 4xN or 3xN MIMO WLAN-N Signal with two R&S Signal Generators for Transmitter Tests..... | 9 |
| 2.2.2 | Generating a Realistic MxN MIMO WLAN-N Signal for Receiver Test under Static Conditions..... | 13 |
| 2.2.3 | Generating a Realistic MxN MIMO WLAN-N Signal for Receiver Test under Real Word Conditions..... | 15 |
| 3 | WLAN-N User Interface | 17 |
| 3.1 | General Settings for WLAN-N Signals..... | 17 |
| 3.2 | Transmit Antenna Setup..... | 22 |
| 3.2.1 | Antenna and Mapping Setting..... | 23 |
| 3.2.2 | Transmission Chain Matrix..... | 23 |
| 3.3 | Frame Block Configuration..... | 24 |
| 3.4 | PPDU Configuration..... | 27 |
| 3.4.1 | Stream Settings..... | 29 |
| 3.4.2 | Spatial Stream Modulation..... | 29 |
| 3.4.3 | PSDU Bit Rate (CCK/PBCC)..... | 29 |
| 3.4.4 | Data Settings..... | 30 |
| 3.5 | MAC Header and FCS Configuration for Frame Block..... | 34 |
| 3.5.1 | MAC Header and FSC..... | 34 |
| 3.5.2 | 802.11 MAC Frame Control Field..... | 35 |
| 3.6 | MAC Header HT Configuration..... | 38 |
| 3.7 | Spatial Mapping..... | 41 |
| 3.8 | Filter/Clipping Settings..... | 43 |
| 3.8.1 | Filter..... | 43 |

| | | |
|------------|---|------------|
| 3.8.2 | Clipping..... | 45 |
| 3.9 | Trigger/Marker/Clock Settings..... | 46 |
| 3.9.1 | Trigger In..... | 47 |
| 3.9.2 | Marker Mode..... | 51 |
| 3.9.3 | Marker Delay..... | 53 |
| 3.9.4 | Clock Settings..... | 54 |
| 3.9.5 | Global Settings..... | 55 |
| 4 | Remote-Control Commands..... | 57 |
| 4.1 | General Commands..... | 57 |
| 4.2 | Filter/Clipping Settings..... | 63 |
| 4.3 | Trigger Settings..... | 69 |
| 4.4 | Marker Settings..... | 75 |
| 4.5 | Clock Settings..... | 81 |
| 4.6 | Frame Configuration..... | 83 |
| | List of Commands..... | 112 |
| | Index..... | 116 |

1 Preface

1.1 Documentation Overview

The user documentation for the R&S Signal Generator consists of the following parts:

- Online Help system on the instrument,
- "Quick Start Guide" printed manual,
- Documentation CD-ROM with:
 - Online help system (*.chm) as a standalone help,
 - Operating Manuals for base unit and options,
 - Service Manual,
 - Data sheet and specifications,
 - Links to useful sites on the R&S internet.

Online Help

The Online Help is embedded in the instrument's firmware. It offers quick, context-sensitive access to the complete information needed for operation and programming. The online help contains help on operating the R&S Signal Generator and all available options.

Quick Start Guide

This manual is delivered with the instrument in printed form and in PDF format on the Documentation CD-ROM. It provides the information needed to set up and start working with the instrument. Basic operations and an example of setup are described. The manual includes also general information, e.g., Safety Instructions.

Operating Manuals

The Operating Manuals are a supplement to the Quick Start Guide. Operating Manuals are provided for the base unit and each additional (software) option.

These manuals are available in PDF format - in printable form - on the Documentation CD-ROM delivered with the instrument. In the Operating Manual for the base unit, all instrument functions are described in detail. Furthermore, it provides an introduction to remote control and a complete description of the remote control commands with programming examples. Information on maintenance, instrument interfaces and error messages is also given.

In the individual option manuals, the specific instrument functions of the option are described in detail. For additional information on default settings and parameters, refer to the data sheets. Basic information on operating the R&S Signal Generator is not included in the option manuals.

These manuals can also be ordered in printed form (see ordering information in the data sheet).

Service Manual

This Service Manual is available in PDF format - in printable form - on the Documentation CD-ROM delivered with the instrument. It describes how to check compliance with rated specifications, on instrument function, repair, troubleshooting and fault elimination. It contains all information required for repairing the instrument by the replacement of modules.

This manual can also be orderd in printed form (see ordering information in the data sheet).

Release Notes

The release notes describe new and modified functions, eliminated problems, and last minute changes to the documentation. The corresponding firmware version is indicated on the title page of the release notes. The current release notes are provided in the Internet.

1.2 Typographical Conventions

The following text markers are used throughout this documentation:

| Convention | Description |
|-------------------------------------|--|
| "Graphical user interface elements" | All names of graphical user interface elements on the screen, such as dialog boxes, menus, options, buttons, and softkeys are enclosed by quotation marks. |
| KEYS | Key names are written in capital letters. |
| File names, commands, program code | File names, commands, coding samples and screen output are distinguished by their font. |
| <i>Input</i> | Input to be entered by the user is displayed in italics. |
| Links | Links that you can click are displayed in blue font. |
| "References" | References to other parts of the documentation are enclosed by quotation marks. |

2 IEEE 802.11n WLAN-N Signal Generation

The R&S Signal Generator provides you with the ability to generate signals in accordance with the Wireless LAN standards IEEE 802.11n.

The R&S Signal Generator supports all mandatory and almost all optional features of the IEEE 802.11n standard.

The following list gives an overview of the main features:

- Support of up to four Tx antennas
- 20MHz and 40MHz bandwidth
- Support of all three operation modes
- Support of all transmission modes
- Additional support of the CCK and PBCC frames in accordance with IEEE802.11a/b/g standard.
- Support of STBC (Space Time Block Coding) and Spatial Multiplexing
- Configurable number of spatial streams, space time streams and additional spatial streams, as well as configurable modulation per spatial stream
- Support of short guard interval
- Configurable state of the scramble, interleaver, time domain windowing and channel coding
- Configurable PPDU, MAC header and FSC
- Integrated frame block concept for the generation of sequence of cascaded frame blocks with different configurations and data rates.
- Support of simple diversity and MIMO tests (Frequency Flat MIMO channel simulation) without additional channel simulator
- Simulation of real-time MIMO channel condition for instruments equipped with the fading options R&S SMU/AMU-K74/-B14/-B15.

2.1 Signal Overview

IEEE 802.11n is the extension of the WLAN IEEE 802.11a/g standard to nominal peak data rates of 600 Mbps. Like IEEE 802.11a/g, also IEEE 802.11n is based on OFDM. Additionally, IEEE 802.11n uses MIMO technology, up to 40 MHz bandwidth and special coding for increased throughput. The extension towards higher data rates is also known as high throughput mode (HT mode) of 802.11n, whereas the non-HT mode can be seen as the part of 802.11n, which is backwards compatible to 802.11a/g.

2.1.1 Operation Modes

The IEEE802.11n standard defined the following three operation modes:

- Legacy mode

This mode is provided for backwards compatibility with the IEEE 802. a/g standard. The mode is also known as Non-HT mode.

- **Mixed Mode**
A legacy preamble and header (L-STF, L-LTF and L-SIG) are wrapping the HT part of the frame so that the frame is complying with OFDM-PHY and ERP-OFDM-PHY corresponding to 802.11a/g respectively.
- **Green Field**
In this mode, frames are being transmitted in a new high throughput format that does not comply with the legacy mode. Green Field is an optional mode.

The [figure 2-1](#) shows the packet formats of the different operation modes that can be triggered by a device supporting the IEEE 802.11n standard.

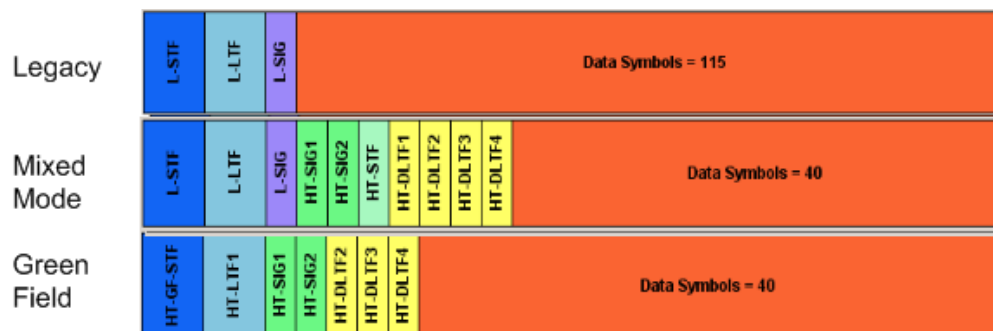

Fig. 2-1: PLCP Packet format for IEEE 802.11n

The [table 2-1](#) gives an overview of the frequency domain operation modes of the physical layer. Note that the duplicate mode corresponds to repeating the same complex numbers modulating the sub-carriers of the upper channel on the lower channel.

Table 2-1: Frequency Domain PHY Operation

| | |
|-----------------------|--|
| LM | Legacy mode as in IEEE 802.11 a/g Additionally the CCK and PBCC frames as in IEEE 802.11b/g |
| HT-Mode | Frequency: 20 MHz and 40 MHz, 1 (4 spatial streams (HT Duplicate Mode included) |
| Duplicate Non-HT Mode | IEEE 802.11a OFDM-PHY format, 20 MHz and 40 MHz dual operation, upper channel rotated by 90° relative to lower channel |
| Upper Mode | Non-HT/HT frame in the upper 20 MHz channel |
| Lower Mode | Non-HT/HT frame in the lower 20 MHz channel |

When operating in the OFDM 20 MHz mode, there are 64 sub-carriers available; the migration to 40 MHz mode offers 128 sub-carriers with the same frequency spacing of 312.5 KHz.

2.1.2 Signal Generation

The generation of an IEEE 802.11n signal is done in multiple steps. In high throughput mode (HT mode), the data of a single user is specially coded and transmitted via up to four Tx antennas.

In the R&S Signal Generator, the mapping of the Tx antennas' signals to the output paths of the instrument can be configured. This function can be used for the simulation of frequency flat MIMO channel, i.e. one carrier analysis like BER tests for instance. Another application of these configurable mapping is the possibility to generate a combined signal from different antennas in case of one path instrument or limited number of baseband paths.

The figure below shows the signal flow for generation of such a signal in HT mode.

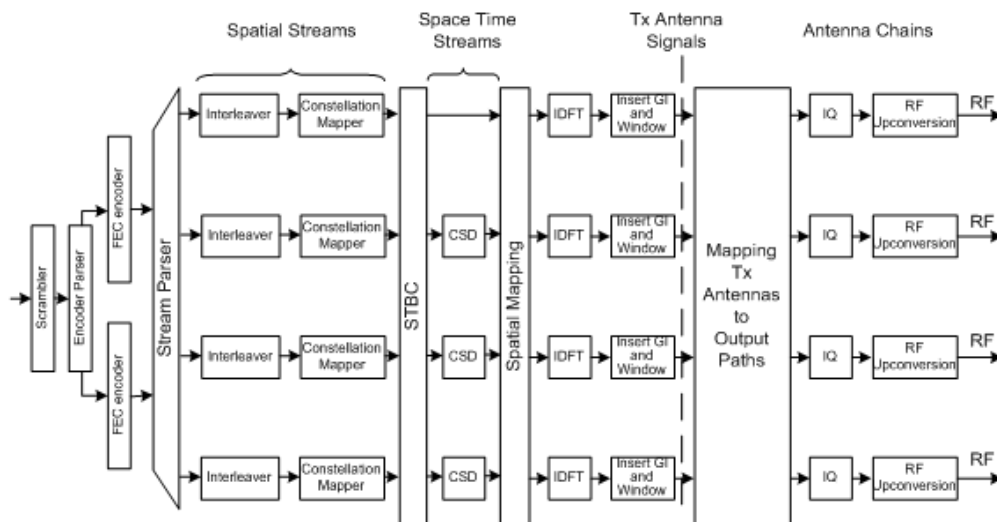

Fig. 2-2: IEEE 802.11 n Transmission chain

2.2 Typical Workflows

The R&S Signal Generator equipped with the option digital standard IEEE 802.11n WLAN-N allows you to generate signals for different transmitter and receiver tests scenarios.

The test scenarios require different number of baseband paths, i.e. instruments. For receiver test for example, the number of the Rx antenna to be simulated simultaneously determines the number of the required basebands of one or more instruments, since one baseband generates the signal of one Rx antenna. In case of transmitter test applications, the number of the Tx antenna to be simulated determines the number of the required basebands of one or more instruments, since one baseband generates the signal of one Tx antenna.

This chapter provides examples of some typical generic workflows and setups for working with this option.

2.2.1 Generating a 4xN or 3xN MIMO WLAN-N Signal with two R&S Signal Generators for Transmitter Tests

This example shows the connection and configuration of two two-path instruments for the generation of WLAN-N signal for transmitter tests. Signal generated in this way can

be additionally fed to a fading simulator (requires option R&S SMU/AMU-K74/B14/B15) for the simulation of realistic MxN MIMO channel conditions (see [chapter 2.2.3, "Generating a Realistic MxN MIMO WLAN-N Signal for Receiver Test under Real Word Conditions"](#), on page 15).

The 4xN and 3xN MIMO WLAN-N signal generation scenario requires two two-path instruments.

The instruments have to be configured and connected as described in the following sections. Since the configuration and connection of the instruments is identical for both scenarios, only the 4xN MIMO case is explained.

Connecting two two-path R&S Signal Generators for 4xN MIMO WLAN-N signal generation

Connect the instruments as follow:

1. To provide the instruments with reference frequency, connect either the inputs REF IN of both instruments to the external reference source or connect the output REF OUT of the first instrument (the R&S Signal Generator that will simulate Tx 1) to the input REF IN of the second one.
2. Provide an external trigger source to the inputs TRIGGER 1 for both paths of both instruments.
3. Avoid unnecessary cable lengths and branching points.

The figure below shows the cabling of two two-path R&S Signal Generators for generating a 4xN MIMO WLAN-N signal.

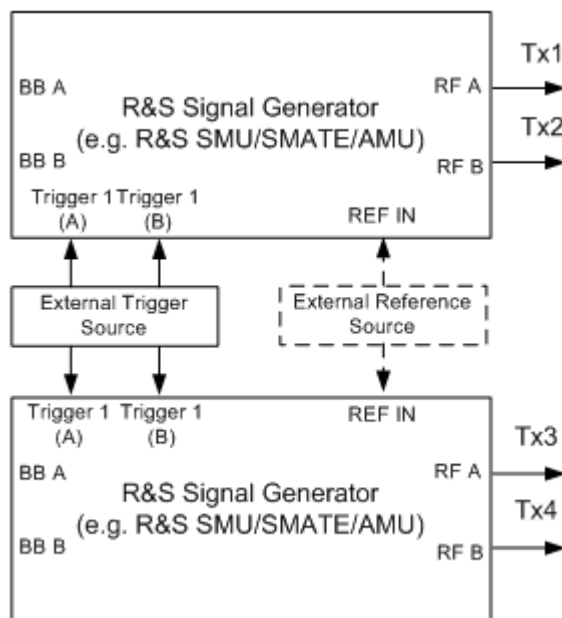
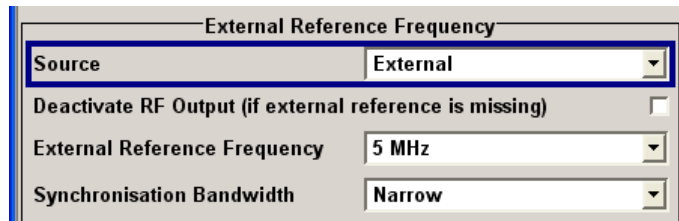

Fig. 2-3: Connecting two two-path R&S Signal Generators for the generation of 4xN MIMO WLAN-N signal

Configuring two R&S Signal Generators for MxN MIMO Simulation

1. Configure the Reference Oscillator Settings, depending on whether an External Reference Source or the Reference Signal (REF OUT) of the first instrument is used.
 - a) Select "External Reference Frequency Source" for both instruments and configure the Synchronization Bandwidth and the External Reference Frequency accordingly.



SCPI command: `SOUR:ROSC:SOUR EXT`

- b) Use the Reference Frequency of the first instrument, i.e. select an "Internal Reference Frequency Source" for the first instrument and an External one for the second instrument.

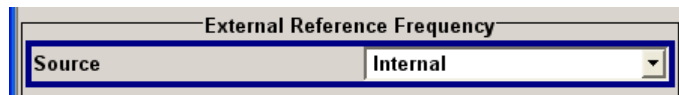

SCPI command (R&S Signal Generator #1):

`SOUR:ROSC:SOUR INT`

SCPI command (R&S Signal Generator #2):

`SOUR:ROSC:SOUR EXT`

2. For both instruments, select an "External Trigger Source".



SCPI command:

`SOUR:BB:WLNN:TRIG:SOUR EXT | BEXT`

3. Configure the first instrument to generate the desired WLAN-N signal:
 - a) In the WLAN-N main menu of the first instrument, enable signal generation in coupling mode (enable parameter "Configure Baseband B from Baseband A").



SCPI command:

`SOUR:BB:WLNN:PATH:COUP:STAT ON`

- b) In the "Tx Antenna Setup" menu of the first instrument, select four "Antennas". The number of the Tx Antennas determines the value M in the MxN MIMO system and the number of the transmission chains.

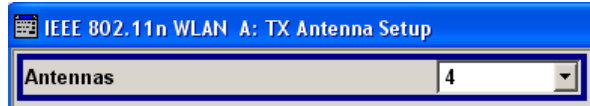

SCPI command:

```
SOUR:BB:WLNN:ANT:MODE A4
```

- c) In the "Tx Antenna Setup" menu of the first instrument, enable the Baseband A of the instrument to generate the Tx 1 signal and respectively the Baseband B to generate the Tx 2 signal.

Use the default values of the transmission chain matrix.

| | Output | File |
|----|------------|------|
| 01 | Baseband A | |
| 02 | Baseband B | |
| 03 | Off | |
| 04 | Off | |

SCPI command:

```
SOUR:BB:WLNN:ANT:TCH1:OUTP:DEST BB
```

```
SOUR:BB:WLNN:ANT:TCH2:OUTP:DEST BB_B
```

```
SOUR:BB:WLNN:ANT:TCH3:OUTP:DEST OFF
```

```
SOUR:BB:WLNN:ANT:TCH4:OUTP:DEST OFF
```

- d) To enable the R&S Signal Generator to generate a WLAN-N signal of antennas with different power level, set the power level of the corresponding path to the desired level in the header display of the instrument.

SCPI command:

```
SOUR:POW -30
```

```
SOUR2:POW -20
```

- e) Use the default "Frame Block Configuration" settings or adjust them as required.
 f) Use the default "PPDU Configuration" settings or adjust them if necessary to, for instance, add redundancy.
 g) Enable signal generation.

SCPI command:

```
SOUR:BB:WLNN:STAT ON
```

4. Enable the second instrument to generate the Tx 3 and Tx 4 of the same WLAN-N signal:

- a) Save the settings of the first instrument by means of the "Save/Recall" function and copy the settings file to USB stick, external USB HDD, or use a LAN connection to transfer the settings file.

SCPI command (R&S Signal Generator #1):

```
SOUR:BB:WLNN:SETT:STOR "c:/11n_Settings/wlann_settings1"
```

- b) Connect the USB stick or the USB HDD to USB connector of Instrument#2 and copy the settings file to the instrument's target directory, e.g. `c:/11n_Instrument1`.
 - c) Load the settings file of R&S Signal Generator #1 to R&S Signal Generator #2.
SCPI command (R&S Signal Generator #2):

```
SOUR:BB:WLNN:SETT:STOR "c:/11n_Instrument1/wlann_settings1"
```
 - d) In the "Tx Antenna Setup" menu of the second instrument, enable the Baseband A of the instrument to generate the Tx 3 signal and respectively the Baseband B to generate the Tx 4 signal and activate the digital standard in the second one.
SCPI command (R&S Signal Generator #2):

```
SOUR:BB:WLNN:ANT:TCH3:OUTP:DEST BB
SOUR:BB:WLNN:ANT:TCH4:OUTP:DEST BB_B
SOUR:BB:WLNN:ANT:TCH1:OUTP:DEST OFF
SOUR:BB:WLNN:ANT:TCH2:OUTP:DEST OFF
SOUR:BB:WLNN:STAT ON
```
5. Send an external trigger signal.

2.2.2 Generating a Realistic MxN MIMO WLAN-N Signal for Receiver Test under Static Conditions

Generating a Realistic MxN MIMO WLAN-N Signal for Receiver Test under Static Conditions

This example shows you how to enable the R&S Signal Generator to generate a WLAN-N signal for simple diversity and simulation of frequency flat MIMO channel conditions. No additional channel simulator is necessary for this test application.

The figure below shows an example of a simple diversity scenario with three transmission antennas Tx 1 .. Tx 3 and one receiving antenna Rx 1. The channel is represented by the weight coefficients w_1 .. w_3 .

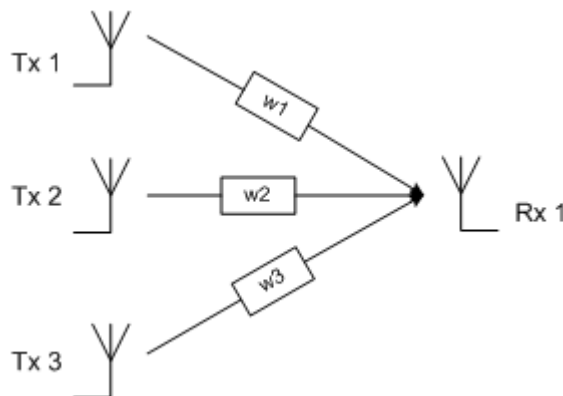

The R&S Signal Generator provides the possibility to weight, sum and map the generated Tx antenna signals to the output(s) of the signal generator, i.e. to simulate a frequency flat MIMO channel conditions for single carrier analysis e.g. BER tests.

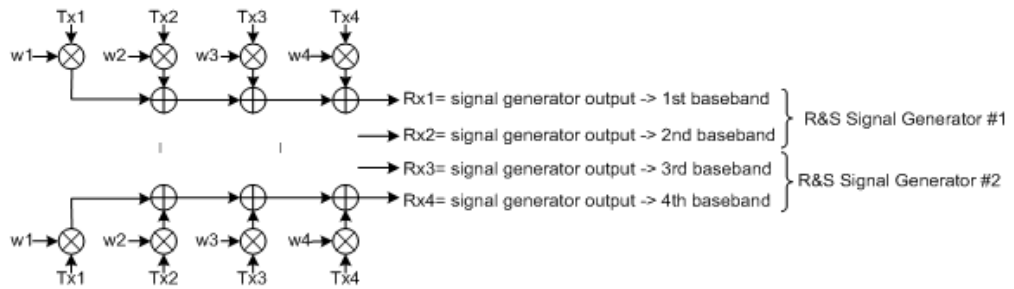

The R&S Signal Generator generates the WLAN-N signal of one Rx antenna per baseband path. Hence, two two-path instruments are required for the Mx4 MIMO receiver testing and respectively one two-path instrument or two one-path instruments for the Mx2 MIMO receiver testing.

To generate a realistic WLAN-N MIMO signal under static conditions, configure the instrument(s) as follow:

1. Use the default "Frame Block Configuration" settings or adjust them as required.
2. Use the default "PPDU Configuration" settings or adjust them if necessary to, for instance, add redundancy.
3. In the "Tx Antenna Setup" menu, select the number of "Tx Antennas" to be simulated. The number of the Tx Antennas determines the value M in the MxN MIMO system and the number of the transmission chains.

SCPI command:

```
SOUR:BB:WLNN:ANT:MODE A3
```

4. Configure the subcarrier to be analyzed, i.e. configure the "Spatial Mapping Mode" and set the "Time Shifts".

| | | Transmit Matrix | | | Index k |
|--------------|--------|----------------------|----------------------|----------------------|---------|
| | | Space Time Stream #1 | Space Time Stream #2 | Space Time Stream #3 | 20 |
| Time Shift 1 | -10 ns | 1.00 | 1.00 | 1.00 | 1.00 |
| Tx 1 | | 0.00 | 0.00 | 0.00 | 0.00 |
| Time Shift 2 | 0 ns | -1.00 | 1.00 | -1.00 | 1.00 |
| Tx 2 | | 0.00 | 0.00 | 0.00 | 0.00 |
| Time Shift 3 | 10 ns | -1.00 | -1.00 | 1.00 | 1.00 |
| Tx 3 | | 0.00 | 0.00 | 0.00 | 0.00 |
| Time Shift 4 | 0 ns | 1.00 | -1.00 | -1.00 | 1.00 |
| | | 0.00 | 0.00 | 0.00 | 0.00 |

SCPI command:

```
SOUR:BB:WLNN:FBL1:SMAP:MODE EXP
```

```
SOUR:BB:WLNN:FBL1:SMAP:TSH1 -10
```

```
SOUR:BB:WLNN:FBL1:SMAP:TSH3 10
```

5. In the Tx Antenna Setup menu, enable the Baseband A to generate the Rx 1 signal.

SCPI command:

```
SOUR:BB:WLNN:ANT:TCH1:OUTP:DEST BB
```

```
SOUR:BB:WLNN:ANT:TCH2|TCH3|TCH4:OUTP:DEST OFF
```

6. Select the mapping coordinates and adjust the weights of the Tx signals in the Transmission Chain Matrix.

| Output | File | Tx 1 | | Tx 2 | | Tx 3 | | | | |
|--------|--------------------|---------|-----------|----------|-----------|--------|-----------|--------|-----------|-----|
| | | 1 Real | Imaginary | 2 Real | Imaginary | 3 Real | Imaginary | 4 Real | Imaginary | |
| O1 | Baseband A ← Rx1 = | 10.0 W1 | 0.00 | -10.0 W2 | 0.00 | 5.0 W3 | 0.00 | 0.00 | 0.00 | Tx1 |
| O2 | Off | 0.00 | 0.00 | 1.00 | 0.00 | 0.00 | 0.00 | 0.00 | 0.00 | Tx2 |
| O3 | Off | 0.00 | 0.00 | 0.00 | 0.00 | 1.00 | 0.00 | 0.00 | 0.00 | Tx3 |
| O4 | Off | 0.00 | 0.00 | 0.00 | 0.00 | 0.00 | 0.00 | 1.00 | 0.00 | Tx4 |

SCPI command:

```
SOUR:BB:WLNN:ANT:SYST CART
```

```
SOUR:BB:WLNN:ANT:TCH1:TX1:REAL 10
```

```
SOUR:BB:WLNN:ANT:TCH1:TX2:REAL -10
```

```
SOUR:BB:WLNN:ANT:TCH1:TX3:REAL 5
```

```
SOUR:BB:WLNN:ANT:TCH1:TX1|TX2|TX3:IMAG 0
```

7. To enable the R&S Signal Generator to generate a WLAN-N signal of antennas with different power level, set the power level of the corresponding path to the desired level in the header display of the instrument.

SCPI command:

```
SOUR:POW -30
```

```
SOUR2:POW -20
```

8. Enable signal generation.

SCPI command:

```
SOUR:BB:WLNN:STAT ON
```

The Baseband A of the R&S Signal Generator will generate the Rx signal as a sum of the three Tx signals, weighted with the selected coefficients.

2.2.3 Generating a Realistic MxN MIMO WLAN-N Signal for Receiver Test under Real Word Conditions

for R&S SMU and R&S AMU instruments only

The simulation of real-time MIMO channel condition requires instruments equipped with the fading options R&S SMU/AMU-K74/-B14/-B15.

The instrument(s) have to be configured as follow:

1. Enable the instrument to generate a 2xN, 3xN or 4xN MIMO WLAN-N signal as described in [chapter 2.2.1, "Generating a 4xN or 3xN MIMO WLAN-N Signal with two R&S Signal Generators for Transmitter Tests"](#), on page 9.

2. Enable the instrument to generate 2xN, 3xN or 4xN MIMO fading signal. Refer to section "Multiple Input Multiple Output" in the description of the Fading Simulator.

3 WLAN-N User Interface

The menu for setting the IEEE 802.11n WLAN-N digital standard is called either from the baseband block or from the menu tree under Baseband.

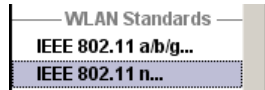

The menu is split into several sections for configuring the standard.

The upper section of the menu is where the IEEE 802.11n WLAN-N digital standard is enabled and the transmission bandwidth is selected.

A button leads to the submenu for loading and saving the IEEE 802.11n WLAN-N configuration.

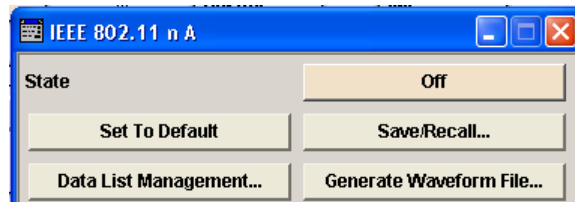

The buttons of the lower menu section lead to submenus for setting the transmission antennas and configuring the frame blocks.

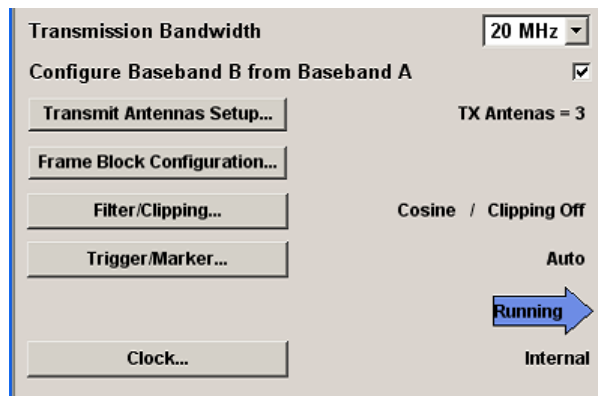

3.1 General Settings for WLAN-N Signals

The upper menu section is where the IEEE 802.11n WLAN-N digital standard is enabled and the basic signal structure is configured.

State

Enables/disables the IEEE 802.11n WLAN-N standard.

Enabling this standard disables all the other digital standards and digital modulation modes (in case of two-path instruments, this affects the same path).

SCPI command:

[:SOURce<hw>] :BB:WLNN:STATe on page 62

Set to default

Calls the default settings. The following table gives an overview of the settings. The preset value for each parameter is specified in the description of the remote-control commands.

| Parameter | Value |
|---|--|
| General Parameters | |
| State | Does not change |
| Transmission Bandwidth | 20 MHz |
| Configure Baseband B from Baseband A | Off |
| TX Antennas | 1 |
| Filter | Cosine |
| Clipping | Off |
| Frame Blocks Configuration | |
| Frame Blocks | 1 |
| Frame Block Type | DATA |
| Frame Blocks State | On |
| Physical Mode | MIXED MODE |
| Tx Mode | HT-20 MHz |
| Frames | 1 |
| Idle Time | 0.1 ms |
| Data Source | PN9 |
| TX Antenna Setup | |
| Antennas | 1 |
| Mapping Coordinates | Cartesian |
| Output | First set Baseband, rest is set to Off |
| Matrix Elements (Real, Imaginary, Magnitude, Phase) | All zero but diagonal = 1 |
| PPDU Configuration | |
| Spatial Streams | 1 |
| Space Time Streams | 1 |
| Extended Spatial Streams | 0 |
| Space Time Block Coding | inactive |
| Stream | QPSK |

| Parameter | Value |
|------------------------------|-------------------|
| Data Bits Paer Symbol | 52 |
| Data Rate (Mbps) | 13 |
| Data Length | 1024 bytes |
| Number of Data Symbols | 158 |
| Preamble/Header Active | ON |
| Guard | Long |
| Scrambler | Off |
| Scrambler Init | 01 |
| Channel Coding | BCC |
| Encoders | 1 |
| Rate | 1/2 |
| Interleaver Active | On |
| Service Field | 0000 |
| Time Domain Windowing Active | On |
| Transition Time | 100 ns |
| Spatial Mapping | |
| Mode | Spatial Expansion |
| Index k | 20 |

SCPI command:

[\[:SOURce<hw>\]:BB:WLNN:PRESet](#) on page 60

Save/Recall

Calls the "Save/Recall" menu.

From the "Save/Recall" menu, the "File Select" windows for saving and recalling IEEE 802.11n WLAN-N configurations and the "File Manager" can be called.



IEEE 802.11n WLAN-N configurations are stored as files with the predefined file extension *.wlann. The file name and the directory they are stored in are user-definable.

The complete settings in the "IEEE 802.11n WLAN-N" menu are saved and recalled.

"Recall WLAN-N setting" Opens the "File Select" window for loading a saved IEEE 802.11n WLAN-N configuration.

The configuration of the selected (highlighted) file is loaded by pressing the "Select" button.

- "Save WLAN-N Opens the "File Select" window for saving the current IEEE 802.11n setting" WLAN-N signal configuration.
The name of the file is specified in the "File name" entry field, the directory selected in the "save into" field. The file is saved by pressing the "Save" button.
- "File Manager" Calls the "File Manager".
The "File Manager" is used to copy, delete, and rename files and to create new directories.

SCPI command:

[:SOURce<hw>] :BB:WLNN:SETTing:CATalog on page 61
 [:SOURce<hw>] :BB:WLNN:SETTing:LOAD on page 62
 [:SOURce<hw>] :BB:WLNN:SETTing:STORE on page 62
 [:SOURce<hw>] :BB:WLNN:SETTing:DELeTe on page 61

Data List Management...

Calls the "Data List Management" menu. This menu is used to create and edit a data list.



All data lists are stored as files with the predefined file extension *.dm_iqd. The file name and the directory they are stored in are user-definable.

The data lists must be selected as a data source from the submenus under the individual function, e.g. in the channel table of the cells.

Note: All data lists are generated and edited by means of the `SOURce:BB:DM` subsystem commands. Files containing data lists usually end with *.dm_iqd. The data lists are selected as a data source for a specific function in the individual subsystems of the digital standard.

Example: Creating and editing the data list:

```
SOUR:BB:DM:DLIS:SEL 'd_list1'
SOUR:BB:DM:DLIS:DATA #B1111010101000001111....
SOUR:BB:DM:DLIS:DATA:APP #B1111010101000001111....
```

SCPI command:

[:SOURce<hw>] :BB:WLNN:FBLOCK<ch>:DATA on page 89
 [:SOURce<hw>] :BB:WLNN:FBLOCK<ch>:DATA:DSElection on page 90

Generate Waveform File...

Calls the "Generate Waveform" menu. This menu is used to store the WLAN-N output stream with "Baseband" destination as ARB signal in a waveform file.

This file can be loaded in the "ARB" menu and processed as multi carrier or multi segment signal.

The file name is entered in the submenu. The file is stored with the predefined file extension *.wv. The file name and the directory it is stored in are user-definable.

SCPI command:

[:SOURce<hw>] :BB:WLNN:WAVeform:CREate on page 63

Transmission Bandwidth

Selects the transmission bandwidth.

If the system bandwidth is set to 20 MHz, all invalid configurations in the frame blocks table are set to the default values.

SCPI command:

[:SOURce<hw>] :BB:WLNN:BWidth on page 58

Configure Baseband B from Baseband A

(The parameter is available only in path A of two-path instruments)

Enables/disables coupling of both baseband paths, i.e. control of both paths via the WLAN N menu.

Note: For instruments with enabled parameter "Configure Baseband B form Baseband A", enabling the WLAN N signal generation in path A disables all other digital standards and digital modulation modes in path B.

- "ON" An active coupling mode is useful for MIMO signal setups. In this case, baseband B is controlled from baseband A and generates an identical setup.
 The assignment which baseband generates the signal of which antenna is done in the .
 Provide an external common trigger source for both baseband paths. Triggering is performed automatically such that both basebands are aligned in time.
 Changing of any parameter restarts the signal generation in both paths. For description on how to enable two R&S Signal Generators to simulate an MIMO WLAN N signal, see [chapter 2.2.1, "Generating a 4xN or 3xN MIMO WLAN-N Signal with two R&S Signal Generators for Transmitter Tests"](#), on page 9.
- "OFF" Corresponds to normal operation, i.e. independent configuration of both paths.

SCPI command:

[:SOURce<hw>] :BB:WLNN:PATH:COUPling[:STATe] on page 60

Transmit Antennas Setup

Calls the menu for configuring the TX antennas.

The menu is described in [chapter 3.2, "Transmit Antenna Setup"](#), on page 22.

SCPI command:

n.a.

Frame Block Configuration

Calls the menu for configuring the frame blocks.

The menu is described in [chapter 3.3, "Frame Block Configuration"](#), on page 24.

SCPI command:

n.a.

Filter/Clipping Settings

Calls the menu for setting baseband filtering and clipping. The current setting is displayed next to the button.

The filter settings are enabled for configuration only for [Transmission Bandwidth](#) set to 20 MHz.

The menu is described in [chapter 3.8, "Filter/Clipping Settings"](#), on page 43.

SCPI command:

n.a.

Trigger/Marker

(Trigger for R&S SMx and R&S AMU instruments only)

Calls the menu for selecting the trigger source, for configuring the marker signals and for setting the time delay of an external trigger signal (see [chapter 3.9, "Trigger/Marker/Clock Settings"](#), on page 46).

The currently selected trigger source is displayed to the right of the button.

SCPI command:

n.a.

Execute Trigger

(R&S SMx and R&S AMU instruments only)

Executes trigger manually.

A manual trigger can be executed only when an internal trigger source and a trigger mode other than "Auto" have been selected.

SCPI command:

[\[:SOURce<hw>\]:BB:WLNN:TRIGger:EXECute](#) on page 70

Clock

(R&S SMx and R&S AMU instruments only)

Calls the menu for selecting the clock source and for setting a delay (see [chapter 3.9, "Trigger/Marker/Clock Settings"](#), on page 46).

SCPI command:

n.a.

3.2 Transmit Antenna Setup

The "Transmit Antenna Setup" is used to map the generated Tx chains to different destinations (Baseband A/B, File or OFF) and makes it possible to combine different Tx antenna signals.

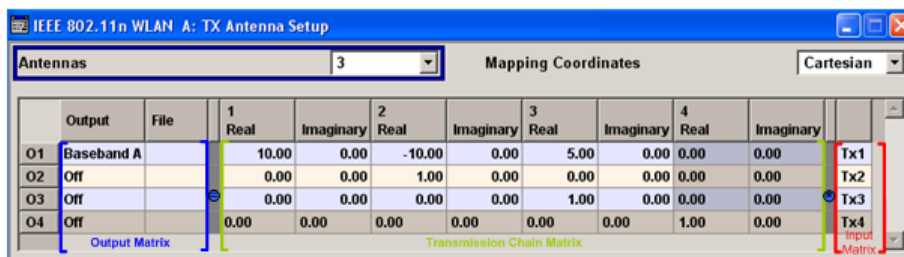

3.2.1 Antenna and Mapping Setting

Antennas

Selects the number of transmit antennas to be used.

For description on how to enable R&S Signal Generator to simulate an MIMO WLAN N signal, see [chapter 2.2, "Typical Workflows"](#), on page 9.

SCPI command:

```
[ :SOURce<hw> ] :BB:WLNN:ANTenna:MODE on page 85
```

Mapping Coordinates

Selects the coordinate system of the transmission chain matrix.

"Cartesian" Sets the Cartesian coordinates system (Real, Imaginary).

"Cylindrical" Sets the cylindrical coordinates system (Magnitude, Phase).

SCPI command:

```
[ :SOURce<hw> ] :BB:WLNN:ANTenna:SYSTEM on page 85
```

3.2.2 Transmission Chain Matrix

The transmission chain matrix can be used to adjust the channel coefficients.

During signal calculation, the R&S Signal Generator evaluates the transmission matrix and takes into account the phase ratios set. However, the power ratio of the antennas is not considered. To enable the R&S Signal Generator to generate a WLAN-N signal of antennas with different power level, set the power level of the corresponding path to the desired level in the header display of the instrument.

Output

Selects the destination of the calculated IQ chains.

"OFF" No mapping takes place.

"Baseband A/B" The IQ chain is output to the selected baseband. Exactly one output stream can be mapped to a baseband.

"File" The IQ chain is saved in a file.

SCPI command:

`[:SOURce<hw>] :BB:WLNN:ANTenna:TCHain<ch>:OUTPut:DESTination`
on page 86

`[:SOURce<hw>] :BB:WLNN:ANTenna:TCHain<ch>:OUTPut:FSElect`
on page 86

Real/Magnitude

Enters the value for the Real or Magnitude coordinates.

SCPI command:

For Cartesian mapping coordinates:

`[:SOURce<hw>] :BB:WLNN:ANTenna:TCHain<ch>:TX<dir>:REAL` on page 87

For Cylindrical mapping coordinates:

`[:SOURce<hw>] :BB:WLNN:ANTenna:TCHain<ch>:TX<dir>:MAGNitude`
on page 87

Imaginary/Phase

Enters the value for the Imaginary or Phase coordinates.

SCPI command:

For Cartesian mapping coordinates:

`[:SOURce<hw>] :BB:WLNN:ANTenna:TCHain<ch>:TX<dir>:IMAGinary`
on page 87

For Cylindrical mapping coordinates:

`[:SOURce<hw>] :BB:WLNN:ANTenna:TCHain<ch>:TX<dir>:PHASe` on page 87

3.3 Frame Block Configuration

In the "Frame Blocks Configuration" menu, the configuration of the selected frame block is done.

| | Type | Physical Mode | Tx Mode | Frames | Idle Time /ms | Data | DList / Pattern | Boost /dB | PPDU | Data Rate /Mbps | State |
|-----|----------|---------------|--------------|--------|---------------|------|-----------------|-----------|-----------|-----------------|-------|
| 1 > | Data | Legacy | PBCC | 5 | 0.200 | PN 9 | | 0.00 | Config... | 11.00 | On |
| 2 | Data | Mixed Mode | HT-20MHz | 3 | 0.100 | PN 9 | | -3.00 | Config... | 13.00 | On |
| 3 | Data | Green Field | HT-40MHz | 2 | 0.100 | PN 9 | | 0.00 | Config... | 27.00 | On |
| 4 | Sounding | Mixed Mode | HT-Duplicate | 3 | 0.100 | PN 9 | | 0.00 | Config... | 6.00 | On |
| 5 | Sounding | Green Field | HT-Lower | 1 | 0.100 | PN 9 | | 0.00 | Config... | 13.00 | On |

Type

Selects the PPDU type.

"DATA" Only Data Long Training Fields are used to probe the channel.

"SOUNDING" Staggered preambles are used to probe additional dimension of the MIMO channel.
Physical type "SOUNDING" is not available for physical layer mode "LEGACY".

SCPI command:

[:SOURCE<hw>] :BB:WLNN:FBLOCK<ch>:TYPE on page 110

Physical Mode

Selects the preamble design.

For physical layer mode LEGACY only physical type DATA is available.

Note: "MIXED MODE" transmissions can be detected by a physical layer transceiver of 802.11a/g OFDM, MAC FCS would however fail.

"LEGACY" Compatible with 802.11a/g OFDM devices. Additionally, CCK/PBCC frames as defined in IEEE 802.11b/g are supported.

"MIXED MODE" For High Throughput (HT) and 802.11a/g OFDM devices.

"GREEN FIELD" For HT only networks.

SCPI command:

[:SOURCE<hw>] :BB:WLNN:FBLOCK<ch>:PMODE on page 103

Tx Mode

Sets the Tx mode.

The available Tx modes are dependent on the physical mode (see table).

| Physical Type | Physical Mode | Tx Mode | Transmission | Bandwidth |
|-------------------|---------------|--------------|--------------|-----------|
| | | | 20 MHz | 40 MHz |
| DATA | LEGACY | L-20MHz | X | X |
| | | L-Duplicate | - | X |
| | | L-Upper | - | X |
| | | L-Lower | - | X |
| | | CCK | X | X |
| | | PBCK | X | X |
| DATA/ SOUNDING | MIXED | HT-20MHz | X | X |
| | MODE/ | HT-40MHz | - | X |
| | GREEN | HT-Duplicate | - | X |
| | FIELD | HT-Upper | - | X |
| | | HT-Lower | - | X |

SCPI command:

[:SOURCE<hw>] :BB:WLNN:FBLOCK<ch>:TMODE on page 110

Frames

Sets the number of frames to be transmitted in the current frame block.

SCPI command:

[:SOURce<hw>] :BB:WLNN:FBLOCK<ch>:FCOUNT on page 92

Idle Time / ms

Sets the time interval separating two frames in this frame block.

SCPI command:

[:SOURce<hw>] :BB:WLNN:FBLOCK<ch>:ITIME on page 93

Data

Selects the data source.

SCPI command:

[:SOURce<hw>] :BB:WLNN:FBLOCK<ch>:DATA on page 89

DList/Pattern

Depending on the selected data source, selects a data list or allows entering a user defined bit pattern.

SCPI command:

[:SOURce<hw>] :BB:WLNN:FBLOCK<ch>:DATA:PATTERN on page 90

[:SOURce<hw>] :BB:WLNN:FBLOCK<ch>:DATA:DSELECTION on page 90

Boost /dB

The parameter assigns a specific RMS power boost/attenuation to the corresponding Frame Block Modulation.

The power level of a Frame Block Modulation is calculated as sum of the power boost and the power level set in the header of the instrument.

Note: At least one Frame Block should have a power boost set to 0 dB value for this gated power mode functionality to work properly.

SCPI command:

[:SOURce<hw>] :BB:WLNN:FBLOCK<ch>:BOOST on page 88

PPDU

Calls the menu for PPDU configuration of the frame blocks.

The menu is described in [chapter 3.4, "PPDU Configuration"](#), on page 27.

SCPI command:

n.a.

Data Rate/Mbps

Indicates the PPDU the data rate.

SCPI command:

[:SOURce<hw>] :BB:WLNN:FBLOCK<ch>:DATA:RATE on page 91

State

Enables the corresponding frame block for transmission.

SCPI command:

[:SOURce<hw>] :BB:WLNN:FBLOCK<ch>:STATe on page 109

Append

Adds a default frame block behind the selected frame block.

SCPI command:

[:SOURce<hw>] :BB:WLNN:FBLOCK:APPend on page 58

Insert

Adds a default frame block before the selected frame block.

SCPI command:

[:SOURce<hw>] :BB:WLNN:FBLOCK<ch>:INSert on page 92

Delete

Deletes the selected frame block.

SCPI command:

[:SOURce<hw>] :BB:WLNN:FBLOCK<ch>:DELete on page 59

Copy

Copies the selected frame block.

SCPI command:

[:SOURce<hw>] :BB:WLNN:FBLOCK<ch>:COPY on page 59

Paste

Pastes the copied frame block behind the selected frame block.

SCPI command:

[:SOURce<hw>] :BB:WLNN:FBLOCK<ch>:PASTe on page 59

3.4 PPDU Configuration

In the "PPDU Configuration" window, the PPDU configuration for all frames in the selected frame block is done.

The parameters available for configuration depend on the selected "PPDU Type", "Physical Layer" and "Tx Mode".

The figure below shows an example of the "PPDU Configuration" window for Sounding "PPDU Type" and "Physical Mode" Green Field.

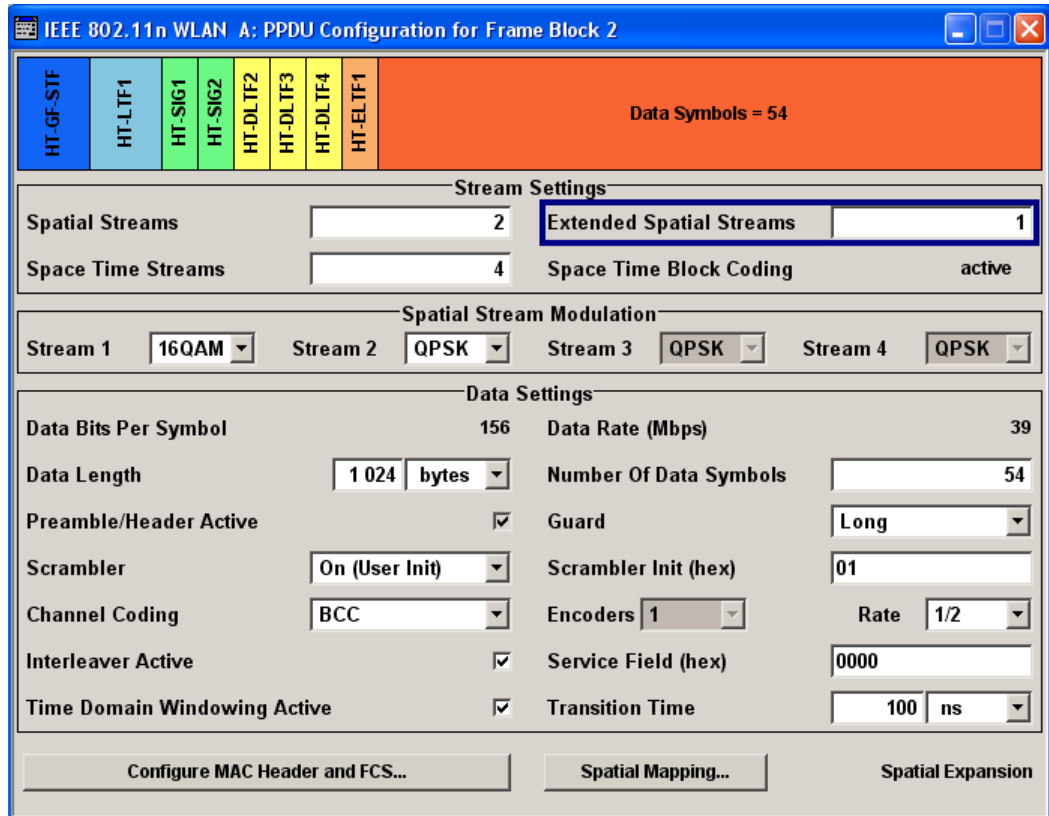

The figure below shows an example of the "PPDU Configuration" window for "Physical Mode Legacy" and "Tx Mode" set to CCK or PBCC .

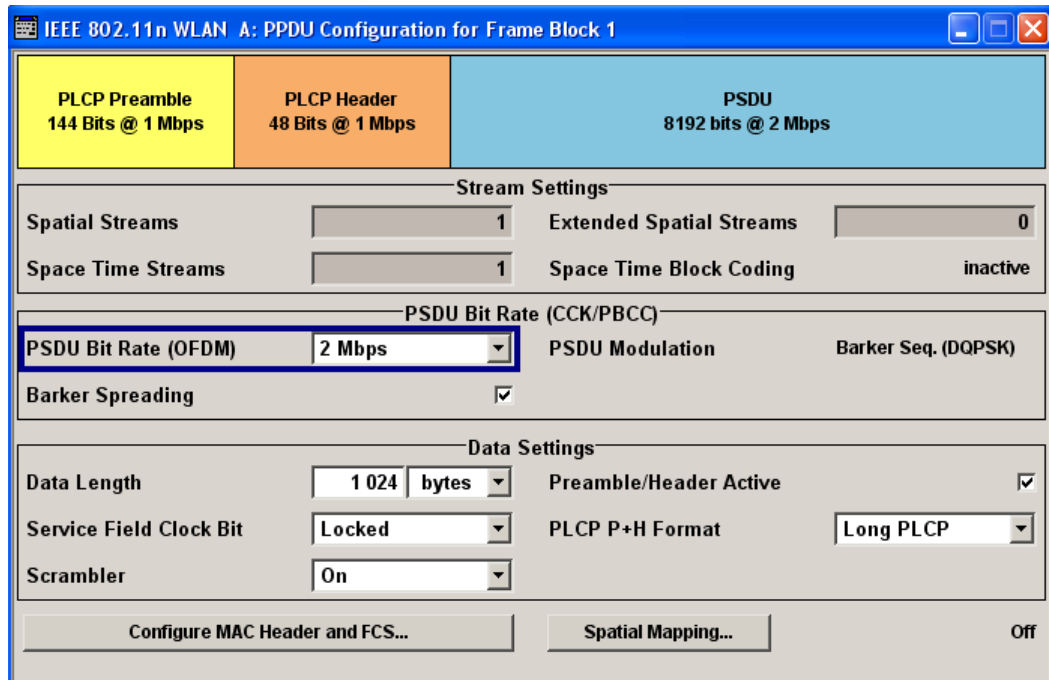

3.4.1 Stream Settings

Spatial Streams

Enters the number of the spatial streams. For physical mode LEGACY, only value 1 is valid. For Tx Mode "HT-Duplicate", only value 1 is valid. In all other cases, the number of spatial streams depends on the number of antennas configured in the "TX Antenna Setup" window.

SCPI command:

[:SOURce<hw>] :BB:WLNN:FBLOCK<ch>:SSTReam on page 108

Space Time Streams

Enters the number of the space time streams. This value depends on the setting in the "Spatial Streams" field. Changing the number of the Spatial Streams immediately changes the value of the Space Time Streams to the same value.

SCPI command:

[:SOURce<hw>] :BB:WLNN:FBLOCK<ch>:STSTream on page 109

Extended Spatial Streams

Enters the value of the extended spatial streams. This field is active for frame block type SOUNDING only to probe additional dimensions to the channel.

SCPI command:

[:SOURce<hw>] :BB:WLNN:FBLOCK<ch>:ESSTream on page 91

Space Time Block Coding

Displays the status of the space time block coding.

SCPI command:

[:SOURce<hw>] :BB:WLNN:FBLOCK<ch>:STBC:STATe on page 109

3.4.2 Spatial Stream Modulation

Stream n

Selects the modulation used for the selected spatial stream.

SCPI command:

[:SOURce<hw>] :BB:WLNN:FBLOCK<ch>:MODulation<st> on page 102

3.4.3 PSDU Bit Rate (CCK/PBCC)

PSDU Bit Rate

(CCK/PBCC Tx Mode only)

Selects the bit rate of the PSDU.

The data rates available are 1 Mbps, 2 Mbps, 5.5 Mbps, 11 Mbps and 22 Mbps. The 1 Mbps data rate is only available if the long PLCP format has been selected. The selection of the data rate also determines the possible modulation modes.

The following table shows the correlation between data rate and modulation.

| Data rate | Possible modulation mode |
|-----------|--|
| 1 Mbps | Barker Sequence (DBPSK) the information data sequence is spread with an 11-chip Barker sequence, chip rate is 11 Mcps |
| 2 Mbps | Barker Sequence (DQPSK) the information data sequence is spread with an 11-chip Barker sequence, chip rate is 11 Mcps |
| 5.5 Mbps | CCK (DQPSK) or PBCC (BPSK) |
| 11 Mbps | CCK (DQPSK) or PBCC (QPSK) |
| 22 Mbps | PBCC (8PSK) |

SCPI command:

[\[:SOURCE<hw>\]:BB:WLNN:FBLOCK<ch>:PSDU:BRATE](#) on page 103

PSDU Modulation

(CCK/PBCC Tx Mode only)

Indicates the modulation type.

The modulation type is determined by the selected PSDU Bit Rate.

SCPI command:

[\[:SOURCE<hw>\]:BB:WLNN:PSDU:MODULATION](#) on page 60

Barker Spreading

(CCK/PBCC Tx Mode only)

Activates/deactivates barker spreading (bit rates 1 Mbps or 2 Mbps only).

SCPI command:

[\[:SOURCE<hw>\]:BB:WLNN:FBLOCK<ch>:PSDU:BSREADING:STATE](#) on page 104

3.4.4 Data Settings

Data Bits Per Symbol

Displays the number of data bits sent by an OFDM symbol on all spatial streams.

SCPI command:

[\[:SOURCE<hw>\]:BB:WLNN:FBLOCK<ch>:DATA:BPSSymbol](#) on page 89

Data Length

The command enters the size of the data field in bytes.

For Data Length = 0, no data field will be generated for the case of a sounding frame.

The maximum data length depends on the physical mode:

- In LEGACY mode, the maximum value is 4061 Bytes.
- In MIXED MODE and GREEN FIELD, the maximum value is 65495 Bytes.

The data length is related to the number of data symbols. Whenever the data length changes, the number of data symbols is updated and vice versa.

SCPI command:

[:SOURCE<hw>] :BB:WLNN:FBLOCK<ch>:DATA:LENGTH on page 90

Preamble/Header Active

Activates/deactivates the preamble and signal fields of the frames in the current frame block.

For data type set to SOUNDING, the preamble and signal field are always activated and cannot be deactivated.

SCPI command:

[:SOURCE<hw>] :BB:WLNN:FBLOCK<ch>:PREAmble:STATe on page 103

Scrambler

Selects the different options for the scrambler.

"OFF" The scrambler is deactivated.

"On (Random Init)" (not for CCK/PBCC)
The scrambler is activated.

The initialization value of the scrambler is selected at random. Each frame has a different random initialization value. This value is also different in case of successive recalculations with the same setting parameters so that different signals are generated for each calculation.

"On (User Init)" (not for CCK/PBCC)
The scrambler is activated.
The initialization value of the scrambler is set to a fixed value that is entered at Scrambler Init (hex). This value is then identical in each generated frame.

"ON" (CCK/PBCC only)
The scrambler is activated.

"Preamble Only" (CCK/PBCC only)
The scrambler is activated.
Only the preamble is scrambled.

SCPI command:

[:SOURCE<hw>] :BB:WLNN:FBLOCK<ch>:SCRambler:MODE on page 104

Channel Coding

Selects whether channel coding (BCC) is used or not.

SCPI command:

[:SOURCE<hw>] :BB:WLNN:FBLOCK<ch>:CODing:TYPE on page 88

Interleaver Active

Activates/deactivates the interleaver of the data field.

SCPI command:

`[:SOURCE<hw>] :BB:WLNN:FBLOCK<ch>:ILEAVER:STATE` on page 92

Time Domain Windowing Active

Activates/deactivates the time domain windowing.

Time domain windowing is a method to influence the spectral characteristics of the signal, which is not stipulated by the standard. However, it does not replace oversampling and subsequent signal filtering.

SCPI command:

`[:SOURCE<hw>] :BB:WLNN:FBLOCK<ch>:TDWINDOWING:STATE` on page 110

Data Rate/Mbps

Indicates the PPDU the data rate.

SCPI command:

`[:SOURCE<hw>] :BB:WLNN:FBLOCK<ch>:DATA:RATE` on page 91

Number Of Data Symbols

Sets the number of data symbols per frame block.

If the number of OFDM data symbols is changed, the generator calculates the data field length as a function of the set PPDU bit rate and displays it at "Data Length".

SCPI command:

`[:SOURCE<hw>] :BB:WLNN:FBLOCK<ch>:DATA:SYMBOLS` on page 91

Guard

Selects whether a long or short guard interval is used for the OFDM guard. In physical mode GREEN FIELD or LEGACY, only long guard intervals are possible. In this case, the field is read-only.

SCPI command:

`[:SOURCE<hw>] :BB:WLNN:FBLOCK<ch>:GUARD` on page 92

Scrambler Init (hex)

Enters the initialization value for scrambling mode User. This value is then identical in each generated frame.

SCPI command:

`[:SOURCE<hw>] :BB:WLNN:FBLOCK<ch>:SCRAMBLER:PATTERN` on page 105

Encoders

Displays the number of encoders to be used. This value depends on the data rate. For data rate ≤ 300 Mps, this value is 1. Otherwise, the number of encoders is 2.

SCPI command:

`[:SOURCE<hw>] :BB:WLNN:FBLOCK<ch>:CODING:ENCODER` on page 88

Rate

Selects the coding rate.

SCPI command:

[\[:SOURCE<hw>\]:BB:WLNN:FBLOCK<ch>:CODING:RATE](#) on page 88

Service Field (hex)

Enters the value of the service field. The standard specifies a default value of 0. Other values can be entered in hexadecimal form for test purposes or future extensions.

SCPI command:

[\[:SOURCE<hw>\]:BB:WLNN:FBLOCK<ch>:SERVICE:PATTERN](#) on page 105

Transition Time

Sets the transition time when time domain windowing is active.

The transition time defines the overlap range of two OFDM symbols. At a setting of 100 ns and if BW = 20 MHz, one sample overlaps.

SCPI command:

[\[:SOURCE<hw>\]:BB:WLNN:FBLOCK<ch>:TTIME](#) on page 110

Service Field Clock Bit (CCK,PBCC)

(available only for CCK and PBCC transport modes)

Sets the Locked Clock Bit in Service Field of the PLCP Header.

Via this flag (bit), the transmitter indicates whether transmission frequency and symbol rate have been derived from the same oscillator. If this is the case (locked), the bit is set to 1, otherwise (not locked) to 0.

SCPI command:

[\[:SOURCE<hw>\]:BB:WLNN:FBLOCK<ch>:PLCP:LCBIT:STATE](#) on page 102

PLCP P+H Format (CCK/PBCC)

(available only for CCK and PBCC transport modes)

Selects the packet type (PPDU format) with long or short PLCP (physical layer convergence protocol).

Depending on the format selected, the structure, modulation and data rate of the PLCP preamble and header are modified.

SCPI command:

[\[:SOURCE<hw>\]:BB:WLNN:FBLOCK<ch>:PLCP:FORMAT](#) on page 102

Configure MAC Header and FCS

Calls the menu of the MAC Header and FCS Configuration to configure the MAC of each frame in this frame block.

The menu is described in [chapter 3.5, "MAC Header and FCS Configuration for Frame Block"](#), on page 34.

SCPI command:

n.a.

Spatial Mapping

Calls the dialog for spatial mapping to configure the spatial mapping to be used for the selected frame block. The menu is described in [chapter 3.7, "Spatial Mapping"](#), on page 41.

SCPI command:
n.a.

3.5 MAC Header and FCS Configuration for Frame Block

In the real IEEE 802.11n system, a MAC (medium access control) header is transmitted in the PPDU prior to the actual data section. This header comprises control information of the MAC layer. It is also possible to protect the PPDU by a frame checksum. These two functions can be controlled in the menu.

| IEEE 802.11 n A: MAC Header and FCS Configuration for Frame Block 1 | | | | | | | | | | |
|---|-------------------|-----------------|-----------------|-----------------|--------------------|--------------------|-----------|-------------|-----------------|----------------|
| MAC Header | | | | | FCS (checksum) | | | | | |
| Frame Control (hex) | Duration/ID (hex) | Address 1 (hex) | Address 2 (hex) | Address 3 (hex) | Sequence Control | Address 4 (hex) | HT Config | Frame Body | FCS | |
| 0000 | 0000 | 0000 0000 0000 | 0000 0000 0000 | 0000 0000 0000 | Enable | 0000 0000 0000 | ... | 0 - 6 bytes | 0 - 65495 bytes | |
| 2 bytes | 2 bytes | 6 bytes | 6 bytes | 6 bytes | 4 bit 12 bit | 6 bytes | | | 4 bytes | |
| | | | | | Start Number (hex) | Start Number (hex) | | | | |
| | | | | | 0 | 000 | | | | |
| | | | | | Incremented Every | Incremented Every | | | | |
| | | | | | 1 packet(s) | 1 packet(s) | | | | |
| MAC Frame Control Field | | | | | | | | | | |
| Protocol Version | Type | Subtype | To DS | From DS | More Frag | Retry | Pwr Mgt | More Data | WEP | Order |
| 00 | 00 | 0000 | 0 | 0 | 0 | 0 | 0 | 0 | 0 | 0 |
| 2 bit (LSBbits) | 2 bit | 4 bit | 1 bit | 1 bit | 1 bit | 1 bit | 1 bit | 1 bit | 1 bit | 1 bit (MSBbit) |

3.5.1 MAC Header and FSC

MAC Header

Activates/deactivates the generation of the MAC Header for the PPDU. If the MAC header is activated, all MAC header fields are enabled for operation.

The individual fields of the MAC header are described in the following.

All values of the MAC fields (except addresses) are entered in hexadecimal form with LSB in right notation. In the data stream, the values are output standard-conformal with the LSB coming first.

SCPI command:

[:SOURCE<hw>] :BB:WLNN:FBlock<ch>:MAC:STATE on page 101

FCS (checksum)

Activates/deactivates the calculation of the FCS (frame check sequence). The standard defines a 32-bit (4-byte) checksum to protect the MAC header and the user data (frame body).

SCPI command:

[:SOURce<hw>] :BB:WLNN:FBLOCK<ch>:MAC:FCS:STATe on page 95

Frame Control

Enters the value of the frame control field.

The MAC frame control field has a length of 2 bytes (16 bits) and is used to define the protocol version, the frame type, sub type, and its function, etc. As an alternative, the individual bits can be set in the lower part of the graph.

SCPI command:

[:SOURce<hw>] :BB:WLNN:FBLOCK<ch>:MAC:FCONtrol on page 94

[:SOURce<hw>] :BB:WLNN:FBLOCK<ch>:MAC:FCONtrol:PVERsion on page 95

[:SOURce<hw>] :BB:WLNN:FBLOCK<ch>:MAC:FCONtrol:TYPE on page 95

[:SOURce<hw>] :BB:WLNN:FBLOCK<ch>:MAC:FCONtrol:SUBType on page 95

[:SOURce<hw>] :BB:WLNN:FBLOCK<ch>:MAC:FCONtrol:TDS on page 95

[:SOURce<hw>] :BB:WLNN:FBLOCK<ch>:MAC:FCONtrol:FDS on page 94

[:SOURce<hw>] :BB:WLNN:FBLOCK<ch>:MAC:FCONtrol:MFRagments
on page 94

[:SOURce<hw>] :BB:WLNN:FBLOCK<ch>:MAC:FCONtrol:RETRy on page 95

[:SOURce<hw>] :BB:WLNN:FBLOCK<ch>:MAC:FCONtrol:PMANagement
on page 95

[:SOURce<hw>] :BB:WLNN:FBLOCK<ch>:MAC:FCONtrol:MDATa on page 94

[:SOURce<hw>] :BB:WLNN:FBLOCK<ch>:MAC:FCONtrol:WEP on page 95

[:SOURce<hw>] :BB:WLNN:FBLOCK<ch>:MAC:FCONtrol:ORDeR on page 94

3.5.2 802.11 MAC Frame Control Field

| 802.11 MAC Frame Control Field | | | | | | | | | | |
|--------------------------------|-------|---------|-------|---------|-----------|-------|---------|-----------|-------|---------------|
| Protocol Version | Type | Subtype | To DS | From DS | More Frag | Retry | Pwr Mgt | More Data | WEP | Order |
| 00 | 00 | 0000 | 0 | 0 | 0 | 0 | 0 | 0 | 0 | 0 |
| 2 bit (LSBits) | 2 bit | 4 bit | 1 bit | 1 bit | 1 bit | 1 bit | 1 bit | 1 bit | 1 bit | 1 bit (MSBit) |

Duration Id

Enters the value of the duration ID field.

Depending on the frame type, the 2-byte field Duration/ID is used to transmit the association identity of the station transmitting the frame or it indicates the duration assigned to the frame type.

SCPI command:

[:SOURce<hw>] :BB:WLNN:FBLOCK<ch>:MAC:DID on page 94

MAC Address

Enters the value of the address fields 1 ... 4.

The MAC header may contain up to four address fields, but not all of them must be available. Each of the 4 address fields can be activated or deactivated. The fields are used for transmitting the basic service set identifier, the destination address, the source address, the receiver address and the transmitter address. Each address is 6 bytes (48 bit) long. The addresses can be entered in hexadecimal form in the entry field of each address field. The least significant byte (LSB) is in left notation.

SCPI command:

[:SOURce<hw>] :BB:WLNN:FBLock<ch>:MAC:ADDRess<st>:STATe on page 93

Sequence Control

Activates/deactivates the sequence control field.

The sequence control field has a length of 2 bytes and is divided in two parts, the fragment number (4 bits) and the sequence number (12 bits) field. A long user data stream to be transmitted is first split up into MSDUs (MAC service data units) which can either be transmitted as PSDU frames or further divided into fragments. The sequence number and the fragment number are then used to number the individual subpackets of the user data stream to be transmitted. Thus, all PSDUs are assigned a consecutive number. This allows the receiver to arrange the data packets in the correct order, to determine whether an incorrectly transmitted packet was retransmitted and to find out whether packets are missing.

If the receiver can detect a packet without an error and does not request a retransmission, the sequence number is incremented by 1 for each packet (the field is reset to 0 at the latest after a count of 4095). The fragment number field is incremented by 1 when another fragment of the current MPDU is transmitted. The start count for the transmission (normally 0) and the number of packets required to increment the corresponding counter can be defined for both numbers. This is done with the parameters "Start Number" and "Incremented every ... packet(s)".

MAC Header and FCS Configuration for Frame Block

Example:

An error-free transmission of 50 packets (no packet retransmission) is to be simulated. The sequence number should be incremented by 1 for each packet. Since no packet is fragmented, the fragment counter can always remain at 0. In this case the following values have to be set:

| Address 2 (hex) | Address 3 (hex) | Sequence Control | | Address 4 (hex) | Frame Body | FCS |
|---------------------------------|--|--|--------|--|----------------|--------|
| Enable <input type="checkbox"/> | Enable <input checked="" type="checkbox"/> | Enable <input checked="" type="checkbox"/> | | Enable <input checked="" type="checkbox"/> | | |
| 000 0000 0000 | 000 AC77 6ED2 | Frag | Sequ | 0002 3ED3 4290 | 0 - 4095 bytes | 4 byte |
| 6 bytes | 6 bytes | 4 bit | 12 bit | 6 bytes | | |

| | |
|-----------------------------------|-------------------------------|
| Start Number (hex) 0 | Start Number (hex) 000 |
| Incremented Every 4 096 packet(s) | Incremented Every 1 packet(s) |

If it is to be simulated that some packets are received incorrectly or if the response of the receiver should be tested when the same packet arrives several times, the number of packets required to increment the sequence number can be set to 2, for example. Each packet will then automatically be sent twice (with identical data).

SCPI command:

`[:SOURCE<hw>] :BB:WLNN:FBLOCK<ch>:MAC:SCONTROL:STATE` on page 101

`[:SOURCE<hw>] :BB:WLNN:FBLOCK<ch>:MAC:SCONTROL:FRAGMENT:START`
on page 100

`[:SOURCE<hw>] :BB:WLNN:FBLOCK<ch>:MAC:SCONTROL:SEQUENCE:START`
on page 101

`[:SOURCE<hw>] :BB:WLNN:FBLOCK<ch>:MAC:SCONTROL:FRAGMENT:INCREMENT`
on page 100

`[:SOURCE<hw>] :BB:WLNN:FBLOCK<ch>:MAC:SCONTROL:SEQUENCE:INCREMENT`
on page 101

Start Number

Sets the start number of the fragment bits or the sequence bits of the sequence control.

SCPI command:

`[:SOURCE<hw>] :BB:WLNN:FBLOCK<ch>:MAC:SCONTROL:FRAGMENT:START`
on page 100

`[:SOURCE<hw>] :BB:WLNN:FBLOCK<ch>:MAC:SCONTROL:SEQUENCE:START`
on page 101

Increment Every

Defines the number of packets required to increment the counter of the fragment bits or the sequence bits of the sequence control.

SCPI command:

`[:SOURCE<hw>] :BB:WLNN:FBLOCK<ch>:MAC:SCONTROL:FRAGMENT:INCREMENT`
on page 100

`[:SOURCE<hw>] :BB:WLNN:FBLOCK<ch>:MAC:SCONTROL:SEQUENCE:INCREMENT`
on page 101

HT Config

Calls the menu for configuring the MAC HT (High Throughput).

Note: Only the physical modes MIXED MODE or GREEN FIELD (QoS Data frames) provide the HT transmission technology. For physical mode LEGACY this configuration field is not indicated.

The menu is described in [chapter 3.6, "MAC Header HT Configuration"](#), on page 38.

SCPI command:

n.a.

Frame Body

Indicates the length of the user data (frame body).

SCPI command:

n.a.

FCS

Indicates the length of the check sum.

SCPI command:

n.a.

3.6 MAC Header HT Configuration

The HT Control Field may be included in any frame except a non-QoS Data frame. The presence of the HT control field in frames carried in a HT PPDU is indicated by setting the order bit in the MAC header. The HT Control Field appears last in the MAC Header, excluding any security fields.

| MAC HT Control Field | | | | | | | | |
|----------------------|---------------|----------|------------------|----------------|------------------|----------------------|----------------------|-----------------------|
| RDG / More PPDU | AC Constraint | Reserved | ZLF Announcement | CSI / Steering | Feedback Request | Calibration Sequence | Calibration Position | Link Adaption Control |
| 0 | 0 | 0000 0 | 0 | 00 | 00 | 00 | 00 | 0000 0000 0000 0000 |
| 1 bit (LSBit) | 1 bit | 5 bit | 1 bit | 2 bit | 2 bit | 2 bit | 2 bit | 16 bit (MSBit) |

QoS Control

Control field (2 Bytes) with an embedded checkbox for activating the control mechanism of QoS Data Frames (Quality of Service).

The QoS solicits an acknowledgement policy from the receiver, according to specific feedback rules. QoS control ensures a high level of transmission performance like high bit rate, low latency or low bit error probability.

Information on contents of the QoS Control Data frame is for example duration request field, TXOP limit, and AP Buffer State or queue size.

SCPI command:

[\[:SOURCE<hw>\]:BB:WLNN:FBLOCK<ch>:MAC:QSCONTROL:STATE](#) on page 100

[\[:SOURCE<hw>\]:BB:WLNN:FBLOCK<ch>:MAC:QSCONTROL](#) on page 99

RDG/More PDU

The RDG/More signal field (LSB, 1 bit) issues the reverse direction grant. When transmitted by an initiator or a responder, this field is interpreted differently.

Transmitted by Initiator

- **0** = No reverse grant.
- **1** = A reverse grant is present, as defined by the Duration/ID field.

Transmitted by Responder

- **0** = The PPDU carrying the MPDU is the last transmission by the responder.
- **1** = The PPDU carrying the MPDU is the last transmission by the responder.

SCPI command:

[\[:SOURCE<hw>\]:BB:WLNN:FBLOCK<ch>:MAC:HTCONTROL:RDGMORE](#) on page 98

AC Constraint

Indicates the access point of the responder (1 bit).

0 = The response may contain data from any TID (Traffic Identifier)

1 = The response may contain data only from the same AC as the last data received from the initiator.

SCPI command:

[\[:SOURCE<hw>\]:BB:WLNN:FBLOCK<ch>:MAC:HTCONTROL:ACCONSTRAINT](#)

on page 96

Reserved

This signal field (5 bit) is currently defined, but not used. It is set to zero by the transmitter and ignored by the receiver.

SCPI command:

[\[:SOURCE<hw>\]:BB:WLNN:FBLOCK<ch>:MAC:HTCONTROL:RESERVED](#)

on page 99

ZLF Announcement

The ZLF Announcement (1 bit) indicates that a ZLF (Zero Length Frame) will be transmitted after the frame.

0 = no ZLF will follow

1 = ZLF will follow

SCPI command:

[\[:SOURCE<hw>\]:BB:WLNN:FBLOCK<ch>:MAC:HTCONTROL:ZLF](#) on page 99

CSI Steering

Sets the position of the CSI feedback (2 bit)

00 = CSI

01 = uncompressed Steering Matrix

10 = compressed Steering Matrix

11 = Reserved

SCPI command:

`[:SOURCE<hw>] :BB:WLNN:FBLOCK<ch>:MAC:HTCONTROL:CSISteering`
on page 97

Feedback Request

Sets the type of feedback (2 bit):

00 = no request

01 = unsolicited feedback only

10 = immediate feedback

11 = aggregated feedback

SCPI command:

`[:SOURCE<hw>] :BB:WLNN:FBLOCK<ch>:MAC:HTCONTROL:FREQUEST`
on page 97

Calibration Sequence

Identifies the calibration sequence (2 bit). The field is included in each frame within the calibration procedure. Its value remains unchanged during one calibration procedure and is incremented each time a new calibration procedure starts.

SCPI command:

`[:SOURCE<hw>] :BB:WLNN:FBLOCK<ch>:MAC:HTCONTROL:CALIBRATION:SEQUENCE` on page 97

Calibration Position

Sets the position in the Calibration Sounding Exchange sequence (2 bit):

00 = Not a calibration frame (Default setting)

01 = Calibration Start

10 = Sounding Response

11 = Sounding Complete

SCPI command:

`[:SOURCE<hw>] :BB:WLNN:FBLOCK<ch>:MAC:HTCONTROL:CALIBRATION:POSITION` on page 96

Link Adaption Control

Sets the parameters of the link adaption control field. The following subfields enable configuring the response signal of the link adaption.

"B0 (1bit) MA - MA payload"

When the MA (Management Action) field is set to 1, the payload of the QoS Null Data MPDU (Medium Access Controller Protocol Data Unit) is interpreted as a payload of the management action frame.

"B1 (1bit) TRQ - Sounding Request"

1 = Request to the responder to transmit a sounding PPDU (Physical layer Protocol Data Unit).

"B2 (1bit) MRQ - MCS Request"

1 = Request for feedback of MCS (Modulation Coding Scheme).

"B3-B5 (3bit) MRS - MRQ Sequence Identifier"

Set by sender to any value in the range '000'-'110' to identify MRQ. = Invalid if MRQ = 0

"B6-B8 (3bit) MFS - MFB Sequence Identifier"

Set to the received value of MRS. Set to '111' for unsolicited MFB.

"B9-B15 (7bit) MFB - MCS Feedback"

Link adaptation feedback containing the recommended MCS. When a responder is unable to provide MCS feedback or the feedback is not available, the MFB is set to 'all-ones' (default value) and also MFS is set to '1'.

SCPI command:

```
[ :SOURce<hw> ] :BB:WLNN:FBLock<ch>:MAC:HTControl:LAControl
```

on page 98

3.7 Spatial Mapping

The Wireless LAN standard IEEE 802.11n builds upon previous 802.11 standards by adding MIMO (Multiple-input multiple-output). MIMO uses multiple transmitter and receiver antennas for increased data throughput via spatial multiplexing and increased range by exploiting the spatial diversity. Mode, time shifts and transmit parameters are defined in the menu "Spatial Mapping for Frame Block".

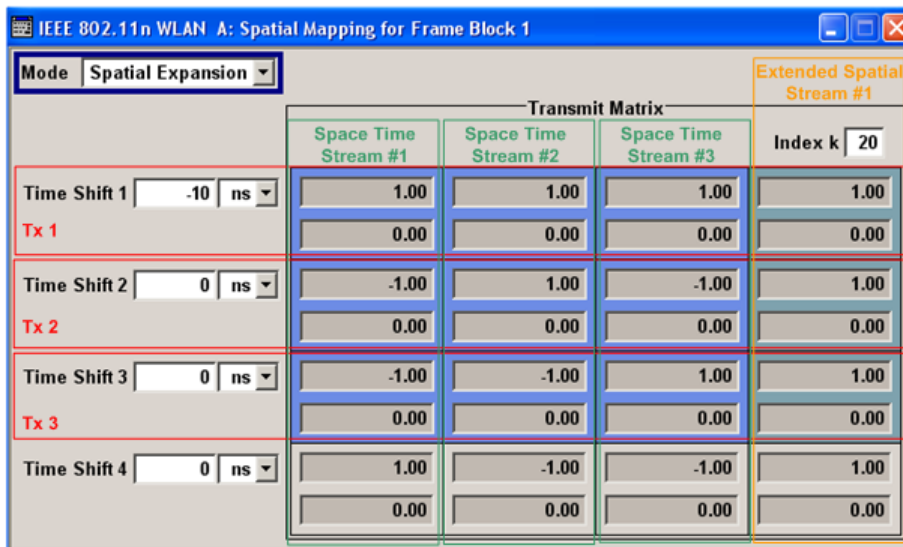

When loaded, the spatial mapping dialog shows the frame block number for which this spatial mapping dialog is loaded. The transmit matrix corresponding to index k will have N_{TX} rows (representing the number of transmit antennas) and N_{STS} columns (representing the space time streams). The text label shows the spatial mapping mode selected in the

dialog which is updated whenever the mode changes. In case of physical layer mode SOUNDING, a second sub-matrix horizontally sided to the transmit matrix with N_{TX} rows and N_{ESS} columns (representing the number of extended spatial streams) will be used as a transmit matrix for the Extended Long Training Fields (ELTF). The values displayed for the transmit matrices are additionally normalized (internally) so that the expectation of IQ sum-power of all antennas is 0 dBm. Additionally for OFF, Direct, and Spatial Expansion, the expected IQ power is the same for all antennas and hence these modes can be intermixed (frame blocks for each) without caring about any power regulation issue. Relative RMS levels are displayed in the dialog for each antenna.

Mode

Selects the spatial mapping mode for the selected frame block. Except of the beamforming mode, the matrix element values are loaded using Info Class Methods.

- "Off" (only "LEGACY" frame)
The spatial mapping mode is switched off automatically.
- "Direct" (only active with physical modes "MIXED MODE" or "GREEN FIELD" when $N_{TX} = N_{STS}$)
Sets the spatial mapping to "Direct" mode.
The transmit matrix is a CSD matrix, that is, a diagonal matrix of unit magnitude and complex values that represent cyclic shifts in the time domain.
- "Spatial Expansion" (only active with physical modes "MIXED MODE" or "GREEN FIELD")
Sets the spatial mapping to "Expansion" mode.
The transmit matrix is the product of a CSD matrix and the Hadamard unitary matrix.
- "Beamforming" (this feature will be supported in further release)
Sets the spatial mapping to "Beamforming" mode.
The transmit matrix is the product of a CSD matrix and the Hadamard unitary matrix.
The "File" button is displayed to open a Browse popup. A file with source format *.bmf can be selected for the beamforming. The file must include 128 4*4 IQ elements (corresponding to the sub-carriers).

SCPI command:

[\[:SOURCE<hw>\]:BB:WLNN:FBLOCK<ch>:SMAPPING:MODE](#) on page 106

[\[:SOURCE<hw>\]:BB:WLNN:FBLOCK<ch>:SMAPPING:BSELECTION](#) on page 106

Index k

Sets the index of the sub-carrier. A matrix is mapped to each sub-carrier. With the exception of $k=0$, the index can be set in the value range of -64 to 63.

SCPI command:

[\[:SOURCE<hw>\]:BB:WLNN:FBLOCK<ch>:SMAPPING:INDEX](#) on page 106

Time Shift

Sets the spatial mapping time shift. This value is relevant for spatial mapping mode Direct and Spatial Expansion only.

SCPI command:

[\[:SOURCE<hw>\]:BB:WLNN:FBLOCK<ch>:SMAPPING:TSHIFT<st>](#) on page 108

I (Transmit Matrix)

Displays the time shift value of element I of the selected row and column of the spatial transmit matrix.

SCPI command:

`[:SOURCE<hw>] :BB:WLNN:FBLOCK<ch>:SMAPPING:ROW<st>:COL<dir>:I`
on page 107

Q (Transmit Matrix)

Displays the time shift value of element Q of the selected row and column of the spatial transmit matrix.

SCPI command:

`[:SOURCE<hw>] :BB:WLNN:FBLOCK<ch>:SMAPPING:ROW<st>:COL<dir>:Q`
on page 108

3.8 Filter/Clipping Settings

The "Filter/Clipping Settings" menu is reached via the WLAN-N main menu.

The filter parameters ("Filter" section) and clipping ("Clipping" section) are defined in this menu.

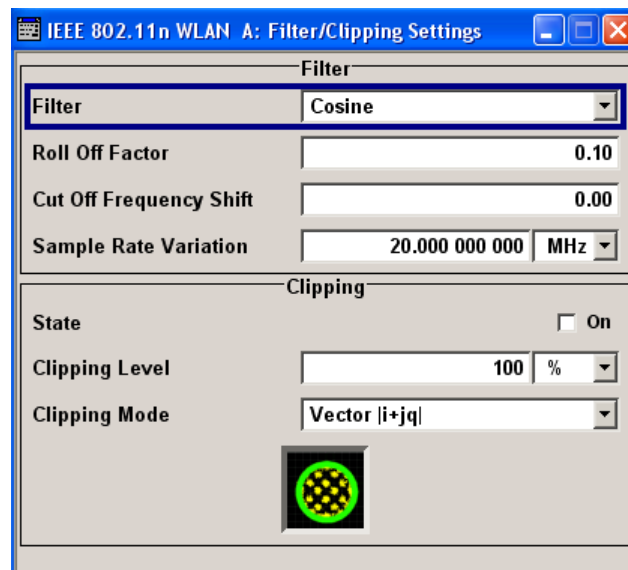

3.8.1 Filter

In the "Filter" section, the settings are made for the baseband filter.



Filter settings are available only for Transmission Bandwidth set to 20 MHz.

Filter

Selects baseband filter.

This opens a selection window containing all the filters available to the instrument.

SCPI command:

[\[:SOURce<hw>\]:BB:WLNN:FILTer:TYPE](#) on page 65

Roll Off Factor or BxT

Enters the filter parameters.

The filter parameter offered (Roll Off factor or BxT) depends on the currently selected filter type. This parameter is always set to the default for each of the predefined filters.

SCPI command:

[\[:SOURce<hw>\]:BB:WLNN:FILTer:PARAmeter:APCO25](#) on page 66

[\[:SOURce<hw>\]:BB:WLNN:FILTer:PARAmeter:COSine](#) on page 66

[\[:SOURce<hw>\]:BB:WLNN:FILTer:PARAmeter:GAUSs](#) on page 67

[\[:SOURce<hw>\]:BB:WLNN:FILTer:PARAmeter:PGAuss](#) on page 68

[\[:SOURce<hw>\]:BB:WLNN:FILTer:PARAmeter:RCOSine](#) on page 68

[\[:SOURce<hw>\]:BB:WLNN:FILTer:PARAmeter:SPHase](#) on page 68

Cut Off Frequency Factor

(This feature is available for filter parameter "Lowpass" only.)

Sets the value for the cut off frequency factor. The cut off frequency of the lowpass filter (ACP and EVM optimization) can be adjusted to reach spectrum mask requirements.

SCPI command:

[\[:SOURce<hw>\]:BB:WLNN:FILTer:PARAmeter:LPASs](#) on page 67

[\[:SOURce<hw>\]:BB:WLNN:FILTer:PARAmeter:LPASSEVM](#) on page 67

Cut Off Frequency Shift

(This feature is available for filter parameter Cosine only.)

Sets the value for the cut off frequency shift. The cut off frequency of the cosine filter can be adjusted to reach spectrum mask requirements.

The value range is -1.0 to 1.0.

SCPI command:

[\[:SOURce<hw>\]:BB:WLNN:FILTer:PARAmeter:COSine:COFS](#) on page 67

Sample Rate Variation

Sets the sample rate of the signal.

A variation of this parameter only affects the ARB clock rate; all other signal parameters remain unchanged. If the sampling rate in the frame configuration menu is changed, this parameter is reset to the chosen sampling rate.

SCPI command:

[\[:SOURce<hw>\]:BB:WLNN:SRATe:VARiation](#) on page 69

Impulse Length

(For WinIQSIM2 only)

Displays the number of filter tabs. If the check box is activated, the most sensible parameter values are selected. The value depends on the coherence check. If the check box is deactivated, the values can be changed manually.

SCPI command:

[\[:SOURCE<hw>\]:BB:WLNN:FILTer:ILENgtH](#) on page 65

[\[:SOURCE<hw>\]:BB:WLNN:FILTer:ILENgtH:AUTO](#) on page 65

Oversampling

(For WinIQSIM2 only)

Determines the upsampling factor. If the check box is activated, the most sensible parameter values are selected. The value depends on the coherence check. If the check box is deactivated, the values can be changed manually.

SCPI command:

[\[:SOURCE<hw>\]:BB:WLNN:FILTer:OSAMpling](#) on page 66

[\[:SOURCE<hw>\]:BB:WLNN:FILTer:OSAMpling:AUTO](#) on page 66

3.8.2 Clipping

The settings for clipping are collected in the "Clipping" section.

Clipping State

Switches baseband clipping on and off.

Baseband clipping is a very simple and effective way of reducing the crest factor of the WLAN-N signal.

WLAN-N signals may have very high crest factors. High crest factors entail two basic problems:

- The nonlinearity of the power amplifier (compression) causes intermodulation which expands the spectrum (spectral regrowth).
- Since the level in the D/A converter is relative to the maximum value, the average value is converted with a relatively low resolution. This results in a high quantization noise.

Both effects increase the adjacent-channel power.

With baseband clipping, all the levels are limited to a settable value ("Clipping Level"). This level is specified as a percentage of the highest peak value. Since clipping is done prior to filtering, the procedure does not influence the spectrum. The EVM however increases.

Since clipping the signal not only changes the peak value but also the average value, the effect on the crest factor is unpredictable. The following table shows the effect of the "Clipping" on the crest factor for typical scenarios.

SCPI command:

[\[:SOURCE<hw>\]:BB:WLNN:CLIPping:STATe](#) on page 64

Clipping Level

Sets the limit for clipping.

This value indicates at what point the signal is clipped. It is specified as a percentage, relative to the highest level. 100% indicates that clipping does not take place.

SCPI command:

[\[:SOURCE<hw>\]:BB:WLNN:CLIPPING:LEVEL](#) on page 64

Clipping Mode

Selects the clipping method. A graphic illustration of the way in which these two methods work is given in the menu.

"Vector $|i + jq|$ " The limit is related to the amplitude $|i + jq|$. The I and Q components are mapped together, the angle is retained (see "Clipping State").



"Scalar $|i| + |q|$ " The limit is related to the absolute maximum of all the I and Q values $|i| + |q|$.



The I and Q components are mapped separately, the angle changes.

SCPI command:

[\[:SOURCE<hw>\]:BB:WLNN:CLIPPING:MODE](#) on page 64

3.9 Trigger/Marker/Clock Settings



The trigger, clock, and marker delay functions are available for R&S SMx and R&S AMU instruments only.

To access this dialog, select "Main Menu > Trigger/Marker".

The "Trigger In" section is where the trigger for the signal is set. Various parameters will be provided for the settings, depending on which trigger source - internal or external - is selected. The current status of signal generation ("Running" or "Stopped") is indicated for all trigger modes.

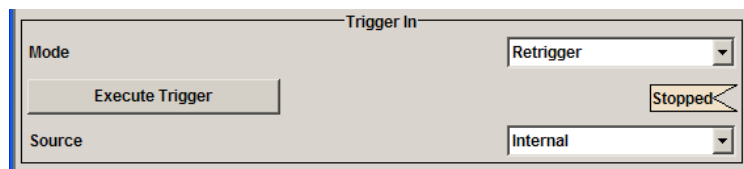

The "Marker Mode" section is where the marker signals at the MARKER output connectors are configured.

| Marker Mode | | | |
|-------------|--------------|-------------------|-----------|
| Marker 1 | Restart | | |
| Marker 2 | Frame | Frame Block Index | 1 |
| | | Frame Index | 1 |
| Marker 3 | Frame Block | Frame Block Index | 1 |
| Marker 4 | On/Off Ratio | On Time | 1 Samples |
| | | Off Time | 1 Samples |

The "Marker Delay" section is where a marker signal delay can be defined, either without restriction or restricted to the dynamic section, i.e., the section in which it is possible to make settings without restarting signal and marker generation.

| Marker Delay | |
|--------------|---------------|
| Marker 1 | 0.000 Samples |
| Marker 2 | 0.000 Samples |
| Marker 3 | 0.000 Samples |
| Marker 4 | 0.000 Samples |

Current Range Without Recalculation

0 2000 Samples

Fix Marker Delay To Current Range

The "Clock Settings" section is where the clock source is selected and - in the case of an external source - the clock type.

| Clock Settings | |
|----------------|----------|
| Clock Source | Internal |

The buttons in the last section lead to submenu for general trigger, clock and mapping settings.

| |
|-----------------------------------|
| Global Trigger/Clock Settings... |
| User Marker / AUX I/O Settings... |

3.9.1 Trigger In



The trigger functions are available for R&S SMx and R&S AMU instruments only.

The Trigger In section is where the trigger for the IEEE 802.11n WLAN-N signal is set. The current status of the signal generation is displayed for all trigger modes.

The "Trigger In" section is where the trigger for the signal is set. Various parameters will be provided for the settings, depending on which trigger source - internal or external - is selected. The current status of signal generation ("Running" or "Stopped") is indicated for all trigger modes.

Trigger Mode

Selects trigger mode.

The trigger mode determines the effect of a trigger on the signal generation.

| | |
|-------------------|---|
| "Auto" | The signal is generated continuously. |
| "Retrigger" | The signal is generated continuously. A trigger event (internal or external) causes a restart. |
| "Armed_Auto" | The signal is generated only when a trigger event occurs. Then the signal is generated continuously. Button "Arm" stops signal generation. A subsequent trigger event (internal with "Execute Trigger" or external) causes a restart. |
| "Armed_Retrigger" | The signal is generated only when a trigger event occurs. Then the signal is generated continuously. Every subsequent trigger event causes a restart. Button "Arm" stops signal generation. A subsequent trigger event (internal with "Execute Trigger" or external) causes a restart. |
| "Single" | The signal is generated only when a trigger event occurs. Then the signal is generated once to the length specified at "Signal Duration". Every subsequent trigger event (internal with "Execute Trigger" or external) causes a restart. |

SCPI command:

[\[:SOURCE<hw>\]:BB:WLNN\[:TRIGGER\]:SEQUENCE](#) on page 75

Signal Duration Unit

Defines the unit for the entry of the length of the signal sequence to be output in the "Single" trigger mode.

SCPI command:

[\[:SOURCE<hw>\]:BB:WLNN:TRIGGER:SLUNIT](#) on page 73

Signal Duration

Defines the length of the signal sequence to be output in the "Single" trigger mode.

It is possible to output deliberately just part of the signal, an exact sequence of the signal, or a defined number of repetitions of the signal.

SCPI command:

[\[:SOURCE<hw>\]:BB:WLNN:TRIGGER:SLLENGTH](#) on page 72

Running/Stopped

Displays the status of signal generation for all trigger modes. This display appears only when signal generation is enabled ("State" On).

- "Running" The modulation signal is generated; a trigger was (internally or externally) initiated in triggered mode.
If "Armed_Auto" and "Armed_Retrigger" have been selected, generation of signals can be stopped with the "Arm" button. A new trigger (internally with "Execute Trigger" or externally) causes a restart.
- "Stopped" The signal is not generated, and the instrument waits for a trigger event (internal or external).

SCPI command:

[\[:SOURce<hw>\]:BB:WLNN:TRIGger:RMODE](#) on page 72

Arm

Stops signal generation. This button appears only with "Running" signal generation in the "Armed_Auto" and "Armed_Retrigger" trigger modes.

Signal generation can be restarted by a new trigger (internally with "Execute Trigger" or externally).

SCPI command:

[\[:SOURce<hw>\]:BB:WLNN:TRIGger:ARM:EXECute](#) on page 69

Execute Trigger

Executes trigger manually. A manual trigger can be executed only when an internal trigger source and a trigger mode other than "Auto" have been selected.

SCPI command:

[\[:SOURce<hw>\]:BB:WLNN:TRIGger:EXECute](#) on page 70

Trigger Source

Selects trigger source. This setting is effective only when a trigger mode other than "Auto" has been selected.

- "Internal" The trigger event is executed by "Execute Trigger".
- "Internal (Base-band A/B)" (two-path instruments only)
The trigger event is executed by the trigger signal from the second path
- "External (TRIGGER 1 / 2)" The trigger event is executed with the aid of the active edge of an external trigger signal.
The trigger signal is supplied via the TRIGGER connector.
The polarity, the trigger threshold and the input impedance of the TRIGGER input can be set in the "Global Trigger/Clock Settings" dialog.

SCPI command:

[\[:SOURce<hw>\]:BB:WLNN:TRIGger:SOURce](#) on page 73

Sync. Output to External Trigger

(enabled for Trigger Source External)

Enables/disables output of the signal synchronous to the external trigger event.

For R&S SMBV instruments:

For one or two or more R&S SMBVs configured to work in a master-slave mode for synchronous signal generation, configure this parameter depending on the provided system trigger event and the properties of the output signal. See the table below for an overview of the required settings.

Table 3-1: Typical Applications

| System Trigger | Application | "Sync. Output to External Trigger" |
|--|---|------------------------------------|
| Common External Trigger event for the master and the slave instruments | All instruments are synchronous to the external trigger event | ON |
| | All instruments are synchronous among themselves but starting the signal from first symbol is more important than synchronicity with external trigger event | OFF |
| Internal trigger signal of the master R&S SMBV for the slave instruments | All instruments are synchronous among themselves | OFF |

"On"

Corresponds to the default state of this parameter.

The signal calculation starts simultaneously with the external trigger event but because of the instrument's processing time the first samples are cut off and no signal is outputted. After elapsing of the internal processing time, the output signal is synchronous to the trigger event.

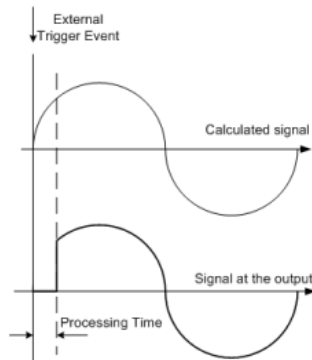

"Off"

The signal output begins after elapsing of the processing time and starts with sample 0, i.e. the complete signal is outputted.

This mode is recommended for triggering of short signal sequences with signal duration comparable with the processing time of the instrument.

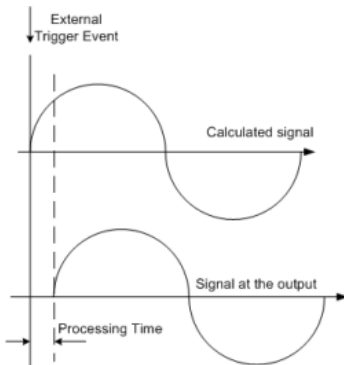

SCPI command:

`[:SOURce<hw>] :BB:WLNN:TRIGger:EXTernal:SYNChronize:OUTPut`
 on page 70

Trigger Delay

Sets the trigger signal delay in samples on external triggering or on internal triggering via the second path.

This enables the R&S Signal Generator to be synchronized with the device under test or other external devices.

For two-path instruments, the delay can be set separately for each of the two paths.

SCPI command:

`[:SOURce<hw>] :BB:WLNN:TRIGger [:EXternal<ch>] :DELay` on page 74

`[:SOURce<hw>] :BB:WLNN:TRIGger:OBASeband:DELay` on page 71

Trigger Inhibit

Sets the duration for inhibiting a new trigger event subsequent to triggering. The input is to be expressed in samples.

In the "Retrigger" mode, every trigger signal causes signal generation to restart. This restart is inhibited for the specified number of samples.

This parameter is only available on external triggering or on internal triggering via the second path.

For two-path instruments, the trigger inhibit can be set separately for each of the two paths.

SCPI command:

`[:SOURce<hw>] :BB:WLNN:TRIGger [:EXternal<ch>] :INHibit` on page 74

`[:SOURce<hw>] :BB:WLNN:TRIGger:OBASeband:INHibit` on page 71

3.9.2 Marker Mode

The marker output signal for synchronizing external instruments is configured in the Marker settings section "Marker Mode".



The R&S SMBV supports only two markers.

Marker Mode

Selects a marker signal for the associated MARKER output.

"Restart" A marker signal is generated at the start of each signal sequence (period = all frame blocks).

"Frame Block" Number of Frame Blocks = 1, that is, a marker signal is generated at the start of each frame block. Otherwise a specific frame block index is given and the whole frame block is marked.

Frame Block Index

SCPI command:

`[:SOURce<hw>] :BB:WLNN:TRIGger:OUTPut<ch>:FBINdex` on page 79

"Frame" Number of Frame Blocks = 1, that is, a marker signal is generated at the start of each frame in the single frame block. Otherwise, the frame block and frame index are entered and the specific frame is masked.

| | |
|-------------------|--------------------------------|
| Frame Block Index | <input type="text" value="1"/> |
|-------------------|--------------------------------|

SCPI command:

[\[:SOURCE<hw>\]:BB:WLNN:TRIGger:OUTPut<ch>:FINDeX](#) on page 79

"Frame Active Part" Number of Frame Blocks = 1, that is, a marker signal is generated to mark every active part of each frame. The active data transfer part (PPDU) of a frame period is marked with high, the inactive part (idle time) with low. This marker can be used to decrease the carrier leakage during inactive signal parts by feeding it into the pulse modulator. Otherwise, the frame block and frame index are entered and the active part of the specific frame is masked.

"Pulse" A regular marker signal is generated. The clock frequency is defined by entering a divider. The frequency is derived by dividing the chip rate by the divider. The input box for the divider opens when Pulse is selected, and the resulting pulse frequency is displayed below it.

| | |
|-----------|--------------------------------|
| Divider | <input type="text" value="2"/> |
| Frequency | 5.500 000 MHz |

SCPI command:

[\[:SOURCE<hw>\]:BB:WLNN:TRIGger:OUTPut<ch>:PULSe:DIVider](#) on page 80

[\[:SOURCE<hw>\]:BB:WLNN:TRIGger:OUTPut<ch>:PULSe:FREQuency](#) on page 80

"Pattern" A marker signal that is defined by a bit pattern is generated. The pattern has a maximum length of 32 bits and is defined in an input field that opens when "pattern" is selected.

| |
|--|
| <input type="text" value="0000 0000"/> |
|--|

SCPI command:

[\[:SOURCE<hw>\]:BB:WLNN:TRIGger:OUTPut<ch>:PATtern](#) on page 80

"ON/OFF Ratio" A regular marker signal that is defined by an ON/OFF ratio is generated. A period lasts one ON and OFF cycle.

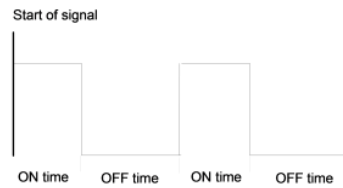

The ON time and OFF time are each expressed as a number of chips and are set in an input field which opens when ON/OFF ratio is selected.

| | | |
|----------|---|-----|
| On Time | 2 | Sym |
| Off Time | 3 | Sym |

SCPI command:

[\[:SOURCE<hw>\]:BB:WLNN:TRIGger:OUTPut<ch>:ONTime](#) on page 78

[\[:SOURCE<hw>\]:BB:WLNN:TRIGger:OUTPut<ch>:OFFTime](#) on page 79

SCPI command:

[\[:SOURCE<hw>\]:BB:WLNN:TRIGger:OUTPut<ch>:MODE](#) on page 78

3.9.3 Marker Delay



The marker delay functions are available for R&S SMx and R&S AMU instruments only.

The delay of the signals on the MARKER outputs is set in the "Marker Delay" section.

The R&S SMBV supports only two markers.

Marker x Delay

Enters the delay between the marker signal at the marker outputs and the start of the frame or slot.

Note: !!ERROR: Document structure missing in note > Must contain atleast one child after 'title'

The input is expressed as a number of symbols/samples. If the setting "Fix marker delay to dynamic range" is enabled, the setting range is restricted to the dynamic range. In this range the delay of the marker signals can be set without restarting the marker and signal.

SCPI command:

[\[:SOURCE<hw>\]:BB:WLNN:TRIGger:OUTPut<ch>:DELay](#) on page 76

Current Range without Recalculation

Displays the dynamic range within which the delay of the marker signals can be set without restarting the marker and signal.

The delay can be defined by moving the setting mark.

SCPI command:

`[:SOURCE<hw>] :BB:WLNN:TRIGger:OUTPut<ch>:DElay:MAXimum` on page 77

`[:SOURCE<hw>] :BB:WLNN:TRIGger:OUTPut<ch>:DElay:MINimum` on page 77

Fix marker delay to current range

Restricts the marker delay setting range to the dynamic range. In this range the delay can be set without restarting the marker and signal.

SCPI command:

`[:SOURCE<hw>] :BB:WLNN:TRIGger:OUTPut:DElay:FIXed` on page 76

3.9.4 Clock Settings



The clock functions are available for R&S SMx and R&S AMU instruments only.

The Clock Settings is used to set the clock source and a delay if required.

Sync. Mode

(for R&S SMBV only)

Selects the synchronization mode.

This parameter is used to enable generation of very precise synchronous signal of several connected R&S SMBVs.

Note: If several instruments are connected, the connecting cables from the master instrument to the slave one and between each two consecutive slave instruments must have the same length and type.

Avoid unnecessary cable length and branching points.

"None" The instrument is working in stand-alone mode.

"Sync. Master" The instrument provides all connected instrument with its synchronisation (including the trigger signal) and reference clock signal.

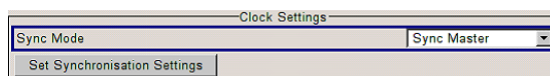

"Sync. Slave" The instrument receives the synchronisation and reference clock signal from another instrument working in a master mode.

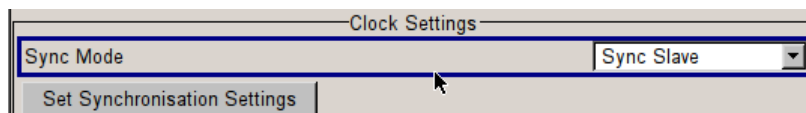

SCPI command:

`[:SOURCE<hw>] :BB:WLNN:CLOCK:SYNChronization:MODE` on page 83

Set Synchronization Settings

(for R&S SMBV only)

Performs automatically adjustment of the instrument's settings required for the synchronization mode, selected with the parameter "Sync. Mode".

SCPI command:

[\[:SOURCE<hw>\]:BB:WLNN:CLOCK:SYNChronization:EXECute](#) on page 83

Clock Source

Selects the clock source.

- | | |
|------------|--|
| "Internal" | The internal clock reference is used to generate the sample clock. |
| "External" | The external clock reference is fed in as the sample clock or multiple thereof via the CLOCK connector. The sample rate must be correctly set to an accuracy of (2 % (see data sheet). The polarity of the clock input can be changed with the aid of "Global Trigger/Clock Settings". In the case of two-path instruments, this selection applies to path A |

SCPI command:

[\[:SOURCE<hw>\]:BB:WLNN:CLOCK:SOURce](#) on page 82

Clock Mode

Enters the type of externally supplied clock.

- | | |
|-------------------|---|
| "Chip" | A sample clock is supplied via the CLOCK connector. |
| "Multiple Sample" | A multiple of the sample clock is supplied via the CLOCK connector; the sample clock is derived internally from this. The Multiplier window provided allows the multiplication factor to be entered. |

SCPI command:

[\[:SOURCE<hw>\]:BB:WLNN:CLOCK:MODE](#) on page 81

Chip Clock Multiplier

Enters the multiplication factor for clock type Multiple.

SCPI command:

[\[:SOURCE<hw>\]:BB:WLNN:CLOCK:MULTiplier](#) on page 82

Measured External Clock

Indicates the measured frequency of the external clock signal. This enables the user to permanently monitor the frequency of the externally introduced clock.

This information is displayed only if the external clock source has been selected.

SCPI command:

CLOCK:INP:FREQ?

3.9.5 Global Settings

This settings are available for R&S SMx and R&S AMU instruments only.

The buttons in this section lead to submenu for general trigger, clock and mapping settings.

Global Trigger/Clock Settings

Calls the "Global Trigger/Clock/Input Settings" dialog.

This dialog is used among other things for setting the trigger threshold, the input impedance and the polarity of the clock and trigger inputs.

In the case of two-path instruments, these settings are valid for both paths.

The parameters in this menu affect all digital modulations and standards, and are described in chapter "Global Trigger/Clock/Input Settings" in the Operating Manual.

User Marker / AUX I/O Settings

Calls the "User Marker AUX I/O Settings" menu, used used to map the connector on the rear of the instruments.

4 Remote-Control Commands

The `SOURce:BB:WLNN` subsystem contains commands for the primary and general settings of the IEEE 802.11n WLAN standard. These settings concern activation and deactivation of the standard, setting the transmission direction, filter, clock, trigger and clipping settings, defining the frame duration and the sequence length, as well as the preset setting.

The commands for defining the frame configuration for physical layer modes OFDM and CCK/PBCC are described in the next section. The commands are divided up in this way to make the comprehensive `SOURce:BB:WLNN` subsystem clearer.

`SOURce<hw>`

For one-path instruments, the keyword `SOURce` is optional and can be omitted.

The numeric suffix to `SOURce` distinguishes between signal generation for path A and path B in the case of two-path instruments:

- `SOURce[1]` = path A
The keyword `SOURce` is optional and can be omitted
- `SOURce2` = path B
The keyword `SOURce` is mandatory, i.e. the command must contain the keyword with suffix 2.

`OUTPut<ch>`

The numeric suffix to `OUTPut` distinguishes between the available markers.

Only two markers are available for the R&S SMBV, i.e. the allowed values for the suffix are 1 or 2.

Placeholder <root>

For commands that read out or save files in the default directory, the default directory is set using command `MMEM:CDIRectory`. The examples in this description use the placeholder `<root>` in the syntax of the command.

- `D:\` - for selecting the internal hard disk of Windows instruments
- `E:\` - for selecting the memory stick which is inserted at the USB interface of Windows instruments
- `/var/<instrument>` - for selecting the internal flash card of Linux instrument, where `<instrument>` is the instrument name, e.g. `smbv`.
- `/usb` - for selecting the memory stick which is inserted at the USB interface of Linux instrument.

4.1 General Commands

| | |
|--|----|
| <code>[:SOURce<hw>]:BB:WLNN:BWidth</code> | 58 |
| <code>[:SOURce<hw>]:BB:WLNN:FBLock:APPend</code> | 58 |
| <code>[:SOURce<hw>]:BB:WLNN:FBLock:APPend</code> | 58 |

| | |
|---|----|
| <code>[SOURce<hw>]:BB:WLNN:IFBLock</code> | 58 |
| <code>[SOURce<hw>]:BB:WLNN:IFBLock</code> | 58 |
| <code>[SOURce<hw>]:BB:WLNN:FBLOCK<ch>:COPY</code> | 59 |
| <code>[SOURce<hw>]:BB:WLNN:CFBBlock</code> | 59 |
| <code>[SOURce<hw>]:BB:WLNN:FBLOCK<ch>:DELeTe</code> | 59 |
| <code>[SOURce<hw>]:BB:WLNN:DFBBlock</code> | 59 |
| <code>[SOURce<hw>]:BB:WLNN:FBLOCK<ch>:PASTE</code> | 59 |
| <code>[SOURce<hw>]:BB:WLNN:PFBlock</code> | 59 |
| <code>[SOURce<hw>]:BB:WLNN:PATH:COUPLing[STATe]</code> | 60 |
| <code>[SOURce<hw>]:BB:WLNN:PRESet</code> | 60 |
| <code>[SOURce<hw>]:BB:WLNN:PSDU:MODulation</code> | 60 |
| <code>[SOURce<hw>]:BB:WLNN:SETTing:CATalog</code> | 61 |
| <code>[SOURce<hw>]:BB:WLNN:SETTing:DELeTe</code> | 61 |
| <code>[SOURce<hw>]:BB:WLNN:SETTing:LOAD</code> | 62 |
| <code>[SOURce<hw>]:BB:WLNN:SETTing:STORe</code> | 62 |
| <code>[SOURce<hw>]:BB:WLNN:STATe</code> | 62 |
| <code>[SOURce<hw>]:BB:WLNN:VERSion</code> | 63 |
| <code>[SOURce<hw>]:BB:WLNN:WAVEform:CREate</code> | 63 |

`[SOURce<hw>]:BB:WLNN:BWidTh <Bwidth>`

The command selects the transmission bandwidth. Whenever the bandwidth changes from 40 MHz to 20 MHz, the frame blocks are validated because some of them could be invalid in 20 MHz (invalid TX Mode).

Parameters:

<Bwidth> BW20|BW40
 *RST: BW40
 Default unit: MHz

Example:

`BB:WLNN:BW BW40`
 sets the transmission bandwidth to 40 MHz.

`[SOURce<hw>]:BB:WLNN:FBLOCK:APPend`

`[SOURce<hw>]:BB:WLNN:FBLOCK:APPend`

The command appends a frame block to the end of the frame blocks list.

Example:

`BB:WLNN:FBL:APP`
 appends a frame block to the end of the frame blocks list.

Usage:

Setting only

`[SOURce<hw>]:BB:WLNN:IFBBlock <Ibblock>`

`[SOURce<hw>]:BB:WLNN:IFBBlock <Ibblock>`

Setting parameters:

<lfblock> float
 Range: 1 to 99

Usage: Setting only

[:SOURce<hw>]:BB:WLNN:FBLock<ch>:COPY
[:SOURce<hw>]:BB:WLNN:CFBLock <Cfblock>

The command copies the selected frame block.

Setting parameters:

<Cfblock> float
 Range: 1 to 100

Example: BB:WLNN:CFBL 5
 copies frame block 5 for later insertion.

Usage: Setting only

[:SOURce<hw>]:BB:WLNN:FBLock<ch>:DELeTe
[:SOURce<hw>]:BB:WLNN:DFBLock <Dfblock>

The command deletes the selected frame block.

Setting parameters:

<Dfblock> float
 Range: 1 to 100

Example: BB:WLNN:DFBL 10
 deletes the selected frame block.

Usage: Setting only

[:SOURce<hw>]:BB:WLNN:FBLock<ch>:PASTE
[:SOURce<hw>]:BB:WLNN:PFBLock <Pfblock>

The command pastes the selected frame block.

Setting parameters:

<Pfblock> float
 Range: 1 to 99

Example: BB:WLNN:PFBL 20
 pastes the frame block to row 20.

Usage: Setting only

[[:SOURce<hw>]:BB:WLNN:PATH:COUPling[:STATe] <State>

Enables/disables coupling of both baseband paths.

Note: For instruments with enabled parameter "Configure Baseband B form Baseband A", enabling the WLAN N signal generation in path A disables all other digital standards and digital modulation modes in path B.

Parameters:

<State>

0|1|OFF|ON

ON

An active coupling mode is useful for MIMO signal setups. In this case, baseband B is controlled from baseband A and generates an identical setup.

OFF

Corresponds to normal operation, i.e. independent configuration of both paths.

*RST: OFF

Example:

```
BB:WLNN:PATH:COUP ON
enables baseband coupling.
```

[[:SOURce<hw>]:BB:WLNN:PRESet

The command produces a standardized default for the IEEE 802.11n standard. The settings correspond to the *RST values specified for the commands.

Example:

```
BB:WLNN:PRESet
resets all the IEEE 802.11n settings to default values.
```

Usage:

Event

[[:SOURce<hw>]:BB:WLNN:PSDU:MODulation?

(available only for CCK and PBCC transport modes)

The command queries the modulation type. The modulation mode depends on the selected PSDU bit rate which depends on the selected physical layer mode (SOUR:BB:WLNN:MODE).

Return values:

<Modulation>

BPSK|QPSK|DBPSK|DQPSK|CCK|PBCC

Example: BB:WLNN:FBL5:PMOD LEG
sets the physical mode to LEGACY.
BB:WLNN:FBL5:TMOD CCK
sets the transport mode
BB:WLNN:FBL5:PSDU:BRAT P2MBPS
sets the PSDU bit rate
BB:WLNN:PSDU:MOD?
queries the modulation mode.
Response: "DQPSK"

Usage: Query only

[:SOURCE<hw>]:BB:WLNN:SETTING:CATalog?

The command reads out the files with IEEE 802.11n settings in the default directory. The default directory is set using command `MMEM:CDIRectory`. Only files with the file extension `*.wlann` will be listed.

Return values:
<Catalog> string

Example: MMEM:CDIR '`<root>\user\wlann`'
sets the default directory to `<root>\user\wlann`.
BB:WLNN:SETT:CAT?
reads out all the files with IEEE 802.11n settings in the default directory.
Response: '`wlann_1`', '`wlann_2`'
the files "`wlann1`" and "`wlann2`" are available.

Usage: Query only

[:SOURCE<hw>]:BB:WLNN:SETTING:DELeTe <Delete>

The command deletes the selected file with IEEE 802.11n WLAN-N settings. The directory is set using command `MMEM:CDIRectory`. A path can also be specified, in which case the files in the specified directory are read. The file extension may be omitted. Only files with the file extension `*.wlann` are listed and can be deleted.

Setting parameters:
<Delete> string

Example: BB:WLNN:SETT:DEL '`wlann_1`'
deletes file '`wlann_1`'.

Usage: Setting only

[[:SOURce<hw>]:BB:WLNN:SETTING:LOAD <Load>

The command loads the selected file with IEEE 802.11n WLAN-N settings. The directory is set using command `MMEM:CDIRECTORY`. A path can also be specified, in which case the files in the specified directory are read. The file extension may be omitted. Only files with the file extension `*.wlann` will be loaded.

Setting parameters:

<Load> string

Example: `BB:WLNN:SETT:LOAD 'wlann_1'`
loads file 'wlann_1'.

Usage: Setting only

[[:SOURce<hw>]:BB:WLNN:SETTING:STORE <Store>

The command stores the current IEEE 802.11n WLAN-N settings into the selected file. The directory is set using command `MMEM:CDIRECTORY`. A path can also be specified, in which case the files in the specified directory are read. Only the file name has to be entered. IEEE 802.11n WLAN-N settings are stored as files with the specific file extensions `*.wlann`.

Setting parameters:

<Store> string

Example: `BB:WLNN:SETT:STOR 'wlann_1'`
stores the current settings into file 'wlann_1'.

Usage: Setting only

[[:SOURce<hw>]:BB:WLNN:STATE <State>

The command activates modulation in accordance with the IEEE 802.11n WLAN-N standard. Activating this standard disables all the other digital standards and digital modulation modes (in case of two-path instruments, this affects the same path).

`BB:WLNN:STAT ON` deactivates the other standards and digital modulation.

Parameters:

<State> 0|1|OFF|ON

*RST: OFF

Example: `BB:WLNN:STAT ON`
activates modulation in accordance with the IEEE 802.11n WLAN standard

[:SOURce<hw>]:BB:WLNN:VERSion?

The command queries the version of the IEEE 802.11n WLAN-N standard underlying the definitions.

Return values:

<Version> string

Example:

BB:WLNN:VERS?
queries the IEEE 802.11n WLAN-N version.

Usage:

Query only

[:SOURce<hw>]:BB:WLNN:WAVEform:CREate <Create>

This command creates a waveform using the current settings of the "WLAN-N" menu. The file name is entered with the command. The file is stored with the predefined file extension *.wv. The file name and the directory it is stored in are user-definable.

Setting parameters:

<Create> string

Example:

MMEM:CDIR '<root>\user\waveform'
sets the default directory to <root>\user\waveform.
BB:WLNN:WAV:CRE 'wlann_1'
creates the waveform file wlann_1.wv in the default directory.

Usage:

Setting only

4.2 Filter/Clipping Settings

| | |
|--|----|
| [:SOURce<hw>]:BB:WLNN:CLIPping:LEVel..... | 64 |
| [:SOURce<hw>]:BB:WLNN:CLIPping:MODE..... | 64 |
| [:SOURce<hw>]:BB:WLNN:CLIPping:STATe..... | 64 |
| [:SOURce<hw>]:BB:WLNN:FILTer:TYPE..... | 65 |
| [:SOURce<hw>]:BB:WLNN:FILTer:ILENgtH..... | 65 |
| [:SOURce<hw>]:BB:WLNN:FILTer:ILENgtH:AUTO..... | 65 |
| [:SOURce<hw>]:BB:WLNN:FILTer:OSAMpling..... | 66 |
| [:SOURce<hw>]:BB:WLNN:FILTer:OSAMpling:AUTO..... | 66 |
| [:SOURce<hw>]:BB:WLNN:FILTer:PARAmeter:APCO25..... | 66 |
| [:SOURce<hw>]:BB:WLNN:FILTer:PARAmeter:COsine..... | 66 |
| [:SOURce<hw>]:BB:WLNN:FILTer:PARAmeter:COsine:COFS..... | 67 |
| [:SOURce<hw>]:BB:WLNN:FILTer:PARAmeter:GAUSS..... | 67 |
| [:SOURce<hw>]:BB:WLNN:FILTer:PARAmeter:LPASS..... | 67 |
| [:SOURce<hw>]:BB:WLNN:FILTer:PARAmeter:LPASSEVM..... | 67 |
| [:SOURce<hw>]:BB:WLNN:FILTer:PARAmeter:PGAuss..... | 68 |
| [:SOURce<hw>]:BB:WLNN:FILTer:PARAmeter:RCOSine..... | 68 |
| [:SOURce<hw>]:BB:WLNN:FILTer:PARAmeter:SPHase..... | 68 |

[\[:SOURce<hw>\]:BB:WLNN:SRATe:VARiation.....](#)69

[:SOURce<hw>]:BB:WLNN:CLIPping:LEVel <Level>

The command sets the limit for level clipping. This value indicates at what point the signal is clipped. It is specified as a percentage, relative to the highest level. 100% indicates that clipping does not take place.

Level clipping is activated with the command `SOUR:BB:WLNN:CLIP:STAT ON`

Parameters:

<Level> float

Range: 1 PCT to 100 PCT
 Increment: 1 PCT
 *RST: 100 PCT

Example:

`BB:WLNN:CLIP:LEV 80PCT`
 sets the limit for level clipping to 80% of the maximum level.
`BB:WLNN:CLIP:STAT ON`
 activates level clipping.

[:SOURce<hw>]:BB:WLNN:CLIPping:MODE <Mode>

The command sets the method for level clipping (Clipping).

Parameters:

<Mode> VECTor|SCALar

VECTor
 The reference level is the amplitude $|i+jq|$.

SCALar
 The reference level is the absolute maximum of the I and Q values.

*RST: VECTor

Example:

`BB:WLNN:CLIP:MODE SCAL`
 selects the absolute maximum of all the I and Q values as the reference level.
`BB:WLNN:CLIP:LEV 80PCT`
 sets the limit for level clipping to 80% of this maximum level.
`BB:WLNN:CLIP:STAT ON`
 activates level clipping.

[:SOURce<hw>]:BB:WLNN:CLIPping:STATe <State>

The command activates level clipping (Clipping). The value is defined with the command `[SOURce:]BB:WLNN:CLIPping:LEVel`, the mode of calculation with the command `[SOURce:]BB:WLNN:CLIPping:MODE`.

Parameters:

<State> 0|1|OFF|ON

*RST: OFF

Example:

BB:WLNN:CLIP:STAT ON
activates level clipping.

[:SOURCE<hw>]:BB:WLNN:FILT:TYPE <Type>

The command selects the filter type.

Parameters:

<Type> RCOSine|COSine|GAUSSs|LGAuss|CONE|COF705|
COEqualizer|COFequalizer|C2K3x|APCO25|SPHase|
RECTangle|PGAuss|LPASSs|DIRac|ENPShape|EWPSshape|
LPASSEVM

*RST: Depends on layer mode

Example:

BB:WLNN:FILT:TYPE COS
sets the filter type COSine.

[:SOURCE<hw>]:BB:WLNN:FILT:ILENGTH <llength>

The command sets the impulse length (number of filter tabs).

Parameters:

<llength> float

Range: 1 to 128

Increment: 1

*RST: 10

Example:

BB:WLNN:FILT:ILEN 10
sets the number of filter tabs to 10.

[:SOURCE<hw>]:BB:WLNN:FILT:ILENGTH:AUTO <Auto>

The command activates/deactivates the impulse length state. If activated, the most sensible parameter values are selected. The value depends on the coherence check.

Parameters:

<Auto> 0|1|OFF|ON

*RST: ON

Example:

BB:WLNN:FILT:ILEN:AUTO ON
the most sensible parameters are selected automatically.

[:SOURce<hw>]:BB:WLNN:FILTer:OSAMpling <Osampling>

The command sets the upsampling factor.

Parameters:

<Osampling> float
 Range: 1 to 32
 *RST: 32

Example:

BB:WLNN:FILT:OSAM 32
 sets the upsampling factor to 32.

[:SOURce<hw>]:BB:WLNN:FILTer:OSAMpling:AUTO <Auto>

The command activates/deactivates the upsampling factor state. If activated, the most sensible parameter values are selected. The value depends on the coherence check. If deactivated, the values can be changed manually.

Parameters:

<Auto> 0|1|OFF|ON
 *RST: ON

Example:

BB:WLNN:FILT:OSAM:AUTO ON
 the most sensible parameters are selected automatically.

[:SOURce<hw>]:BB:WLNN:FILTer:PARAMeter:APCO25 <Apco25>

The command sets the roll-off factor for filter type APCO25.

Parameters:

<Apco25> float
 Range: 0.05 to 0.99
 Increment: 0.01
 *RST: 0.20

Example:

BB:WLNN:PAR:APCO25 0.2
 sets the roll-off factor to 0.2 for filter type APCO25.

[:SOURce<hw>]:BB:WLNN:FILTer:PARAMeter:COSine <Cosine>

The command sets the roll-off factor for the Cosine filter type.

Parameters:

<Cosine> float
 Range: 0.00 to 0.99
 Increment: 0.01
 *RST: 0.35

Example: `BB:WLNN:PAR:COS 0.35`
sets the roll-off factor to 0.35 for filter type Cosine.

[[:SOURce<hw>]:BB:WLNN:FILTer:PARAmeter:COsine:COFS <Cofs>

The command sets the "cut of frequency shift" value for the Cosine filter type.

Parameters:

<Cofs> float
Range: 0.05 to 2.0
*RST: 0.5

Example: `BB:WLNN:FILT:PAR:COS:COFS 0.04`
the "cut of frequency shift" value is set to 0.04.

[[:SOURce<hw>]:BB:WLNN:FILTer:PARAmeter:GAUSs <Gauss>

The command sets the roll-off factor for the Gauss filter type.

Parameters:

<Gauss> float
Range: 0.15 to 2.5
Increment: 0.01
*RST: 0.5

Example: `BB:WLNN:PAR:GAUS 0.5`
sets B x T to 0.5 for the Gauss filter type.

[[:SOURce<hw>]:BB:WLNN:FILTer:PARAmeter:LPASs <Lpass>

The command sets the cut off frequency factor for the Lowpass (ACP optimization) filter type.

Parameters:

<Lpass> float
Range: 0.05 to 2.0
Increment: 0.01
*RST: 0.5

Example: `BB:WLNN:FILT:PAR:LPAS 0.5`
the cut of frequency factor is set to 0.5.

[[:SOURce<hw>]:BB:WLNN:FILTer:PARAmeter:LPASSEVM <Lpassevm>

The command sets the cut off frequency factor for the Lowpass (EVM optimization) filter type.

Parameters:

<Lpassevm> float

Range: 0.05 to 2.0
 Increment: 0.01
 *RST: 0.5

Example:

BB:WLNN:FILT:PAR:LPASSEVM 0.5
 the cut of frequency factor is set to 0.5.

[[:SOURce<hw>]:BB:WLNN:FILT:PAR:PGAuss <Pgauss>

The command sets the roll-off factor for the Pure Gauss filter type.

Parameters:

<Pgauss> float

Range: 0.15 to 2.5
 Increment: 0.01
 *RST: 0.5

Example:

BB:WLLN:FILT:PAR:PGAUS 0.5
 sets B x T to 0.5 for the Pure Gauss filter type.

[[:SOURce<hw>]:BB:WLNN:FILT:PAR:RCOSine <Rcosine>

The command sets the roll-off factor for the Root Cosine filter type.

Parameters:

<Rcosine> float

Range: 0.00 to 0.99
 Increment: 0.01
 *RST: 0.22

Example:

BB:WLNN:PAR:RCOS 0.22
 sets the roll-off factor to 0.22 for filter type Root Cosine.

[[:SOURce<hw>]:BB:WLNN:FILT:PAR:SPHase <Sphase>

The command sets B x T for the Split Phase filter type.

Parameters:

<Sphase> float

Range: 0.15 to 2.5
 Increment: 0.01
 *RST: 2.00

Example: `BB:WLNN:PAR:SPH 0.5`
sets B x T to 0.5 for the Split Phase filter type.

[:SOURce<hw>]:BB:WLNN:SRATe:VARIation <Variation>

Parameters:

<Variation> float

Range: 400 Hz to 40 MHz
Increment: 0.001 Hz
*RST: 2 MHz
Default unit: Hz (c/s)

Example: `BB:WLNN:SRAT:VAR 4000000`
sets the output sample rate to 4 MHz.

4.3 Trigger Settings



The trigger settings are available for R&S SMx and R&S AMU instruments only.

EXTernal<ch>

The numeric suffix to `EXTernal<ch>` distinguishes between the external trigger via the TRIGGER 1 (suffix 1) and TRIGGER 2 (suffix 2) connector.

| | |
|---|----|
| <code>[:SOURce<hw>]:BB:WLNN:TRIGger:ARM:EXECute</code> | 69 |
| <code>[:SOURce<hw>]:BB:WLNN:TRIGger:EXECute</code> | 70 |
| <code>[:SOURce<hw>]:BB:WLNN:TRIGger:EXTernal:SYNChronize:OUTPut</code> | 70 |
| <code>[:SOURce<hw>]:BB:WLNN:TRIGger:OBASeband:DELay</code> | 71 |
| <code>[:SOURce<hw>]:BB:WLNN:TRIGger:OBASeband:INHibit</code> | 71 |
| <code>[:SOURce<hw>]:BB:WLNN:TRIGger:RMODE</code> | 72 |
| <code>[:SOURce<hw>]:BB:WLNN:TRIGger:SLENgth</code> | 72 |
| <code>[:SOURce<hw>]:BB:WLNN:TRIGger:SLUNit</code> | 73 |
| <code>[:SOURce<hw>]:BB:WLNN:TRIGger:SOURce</code> | 73 |
| <code>[:SOURce<hw>]:BB:WLNN:TRIGger[:EXTernal<ch>]:DELay</code> | 74 |
| <code>[:SOURce<hw>]:BB:WLNN:TRIGger[:EXTernal<ch>]:INHibit</code> | 74 |
| <code>[:SOURce<hw>]:BB:WLNN[:TRIGger]:SEQuence</code> | 75 |

[:SOURce<hw>]:BB:WLNN:TRIGger:ARM:EXECute

The command stops signal generation for trigger modes `Armed_Auto` and `Armed_Ret-rigger`. A subsequent internal or external trigger event restart signal generation.

Example:

```
BB:WLNN:TRIG:SOUR INT
sets internal triggering.
BB:WLNN:TRIG:SEQ ARET
sets Armed_Retrigger mode, i.e. every trigger event causes signal
generation to restart.
BB:WLNN:TRIG:EXEC
executes a trigger, signal generation is started.
BB:WLNN:TRIG:ARM:EXEC
signal generation is stopped.
BB:WLNN:TRIG:EXEC
executes a trigger, signal generation is started again.
```

Usage: Event

[:SOURce<hw>]:BB:WLNN:TRIGger:EXECute

The command executes a trigger. The internal trigger source must be selected using the command `BB:WLNN:TRIG:SOUR INT` and a trigger mode other than AUTO must be selected using the command `BB:WLNN:TRIG:SEQ`.

Example:

```
BB:WLNN:TRIG:SOUR INT
sets internal triggering.
BB:WLNN:TRIG:SEQ RETR
sets Retrigger mode, i.e. every trigger event causes signal gen-
eration to restart.
BB:WLNN:TRIG:EXEC
executes a trigger.
```

Usage: Event

[:SOURce<hw>]:BB:WLNN:TRIGger:EXTernal:SYNChronize:OUTPut <Output>

(enabled for Trigger Source External)

Enables/disables output of the signal synchronous to the external trigger event.

For R&S SMBV instruments:

See also [linktarget doesn't exist but @y.link.required='true'](#) for a detailed description of the applications of this setting.

Parameters:

<Output>

0|1|OFF|ON

ON

The signal calculation starts simultaneously with the external trigger event but because of the instrument's processing time the first samples are cut off and no signal is outputted. After elapsing of the internal processing time, the output signal is synchronous to the trigger event.

OFF

The signal output begins after elapsing of the processing time and starts with sample 0, i.e. the complete signal is outputted. This mode is recommended for triggering of short signal sequences with signal duration comparable with the processing time of the instrument.

*RST: ON

Example:

BB:WLNN:TRIG:SOUR EXT

sets external triggering.

BB:WLNN:TRIG:EXT:SYNC:OUTP ON

enables synchronous output to external trigger

[[:SOURce<hw>]:BB:WLNN:TRIGger:OBASband:DELay <Delay>

The command specifies the trigger delay (expressed as a number of samples) for triggering by the trigger signal from the second path.

Parameters:

<Delay>

float

Range: 0 samples to $2^{32}-1$ samples

Increment: 1 sample

*RST: 0 samples

Example:

BB:WLNN:TRIG:SOUR OBAS

sets for path A the internal trigger executed by the trigger signal from the second path (path B).

BB:WLNN:TRIG:OBAS:DEL 50

sets a delay of 50 samples for the trigger.

[[:SOURce<hw>]:BB:WLNN:TRIGger:OBASband:INHibit <Inhibit>

The command specifies the number of samples by which a restart is to be inhibited following a trigger event. This command applies only for triggering by the second path.

Parameters:

<Inhibit> float
 Range: 0 samples to 2³²-1 samples
 Increment: 1 sample
 *RST: 0 samples

Example:

```
BB:WLNN:TRIG:SOUR OBAS
sets for path A the internal trigger executed by the trigger signal
from the second path (path B).
BB:WLNN:TRIG:INH 200
sets a restart inhibit for 200 samples following a trigger event.
```

[[:SOURce<hw>]:BB:WLNN:TRIGger:RMODE?

The command queries the current status of signal generation for all trigger modes with IEEE 802.11n WLAN modulation on.

Return values:

Rmode> RUN|STOP
RUN
 the signal is generated. A trigger event occurred in the triggered mode.
STOP
 the signal is not generated. A trigger event did not occur in the triggered modes, or signal generation was stopped by the command :BB:WLNN:TRIG:ARM:EXECute (armed trigger modes only).

Example:

```
BB:WLNN:TRIG:SOUR EXT
sets external triggering via the TRIGGER 1 connector.
BB:WLNN:TRIG:MODE ARET
selects the Armed_Retrigger mode.
BB:WLNN:TRIG:RMODE?
queries the current status of signal generation.
Response: RUN
the signal is generated, an external trigger was executed.
```

Usage: Query only

[[:SOURce<hw>]:BB:WLNN:TRIGger:SLENGth <Slength>

The command defines the length of the signal sequence to be output in the "Single" trigger mode (SOUR:BB:WLNN:SEQ SING). The input is made in terms of samples.

It is possible to output deliberately just part of the frame, an exact sequence of the frame, or a defined number of repetitions of the frame.

Parameters:

<Slength> float
 Range: 0 samples to $2^{32}-1$ samples
 Increment: 1 sample
 *RST: 26720 samples

Example:

```
BB:WLNN:SEQ SING
sets trigger mode Single.
BB:WLNN:TRIG:SLEN 200
sets a sequence length of 200 samples. The first 200 samples of
the current frame will be output after the next trigger event.
```

[[:SOURce<hw>]:BB:WLNN:TRIGger:SLUnit <Slunit>

The command defines the unit for the entry of the length of the signal sequence (SOUR:BB:WLNN:TRIG:SLEN) to be output in the Single trigger mode (SOUR:BB:WLNN:SEQ SING).

Parameters:

<Slunit> SAMPLE|SEQuence
SAMPLE
 Unit Sample. A single sample is generated after a trigger event.
SEQuence
 Unit Sequence Length. A single sequence is generated after a trigger event.
 *RST: SEQuence

Example:

```
BB:WLNN:SEQ SING
sets trigger mode Single.
BB:WLNN:TRIG:SLUN SEQ
sets unit Sequence for the entry of sequence length.
BB:WLNN:TRIG:SLEN 2
sets a sequence length of 2 sequences. Two sequences will be
output after the next trigger event.
```

[[:SOURce<hw>]:BB:WLNN:TRIGger:SOURce <Source>

The command selects the trigger source.

Parameters:

<Source>

INTernal|EXTernal|BEXTernal|OBASeband

INTernal

Triggering is executed by means of the Trigger command `SOURce<[1] | 2>:BB:WLNN:TRIGger:EXECute` or `*TRG` in the case of remote control and by means of Execute Trigger in the case of manual operation.

EXTernal

Triggering is executed by means of the signal on the TRIGGER 1 connector.

BEXTernal

Triggering is executed by means of the signal on the TRIGGER 2 connector.

OBASeband

Triggering is executed by means of the trigger signal from the second path (two-path instruments only).

*RST: INTernal

Example:

```
BB:WLNN:TRIG:SOUR EXT
```

sets external triggering via the TRIGGER 1 connector.

```
[:SOURce<hw>]:BB:WLNN:TRIGger[:EXTernal<ch>]:DELay <Delay>
```

Parameters:

<Delay>

float

Range: 0 samples to $2^{32}-1$ samples

Increment: 1 sample

*RST: 0 samples

Example:

```
BB:WLNN:TRIG:SOUR EXT
```

sets an external trigger via the TRIGGER 1 connector.

```
BB:WLNN:TRIG:DEL 50
```

sets a delay of 50 samples for the trigger.

```
[:SOURce<hw>]:BB:WLNN:TRIGger[:EXTernal<ch>]:INHibit <Inhibit>
```

The command specifies the number of samples by which a restart is to be inhibited following a trigger event.

Parameters:

<Inhibit>

float

Range: 0 samples to $2^{32}-1$ samples

Increment: 1 sample

*RST: 0 samples

Example: `BB:WLNN:TRIG:SOUR EXT`
 selects an external trigger via the TRIGGER 1 connector.
`BB:WLNN:TRIG:INH 200`
 sets a restart inhibit for 200 samples following a trigger event.

[:SOURce<hw>]:BB:WLNN[:TRIGger]:SEQuence <Sequence>

The command selects the trigger mode.

Parameters:

<Sequence>

AUTO|RETRigger|AAUTo|ARETrigger|SINGle

AUTO

The modulation signal is generated continuously.

RETRigger

The modulation signal is generated continuously. A trigger event (internal or external) causes a restart.

AAUTo

The modulation signal is generated only when a trigger event occurs. After the trigger event the signal is generated continuously. Signal generation is stopped with command `SOUR:BB:WLNN:TRIG:ARM:EXEC` and started again when a trigger event occurs.

ARETrigger

The modulation signal is generated only when a trigger event occurs. The device automatically toggles to RETRIG mode. Every subsequent trigger event causes a restart.

Signal generation is stopped with command

`SOUR:BB:WLNN:TRIG:ARM:EXEC` and started again when a trigger event occurs.

SINGle

The modulation signal is generated only when a trigger event occurs. Then the signal is generated once to the length specified with command `SOUR:BB:WLNN:TRIG:SLen`. Every subsequent trigger event causes a restart.

*RST: AUTO

Example: `BB:WLNN:SEQ AAUT`
 sets the Armed_auto trigger mode; the device waits for the first trigger (e.g. with *TRG) and then generates the signal continuously.

4.4 Marker Settings

This section lists the remote control commands, necessary to configure the markers.



The marker delay settings are available for R&S SMx and R&S AMU instruments only.

OUTput<ch>

The numeric suffix to OUTPut distinguishes between the available markers.

Only two markers are available for the R&S SMBV, i.e. the allowed values for the suffix are 1 or 2.

| | |
|---|----|
| <code>[:SOURce<hw>]:BB:WLNN:TRIGger:OUTPut:DELay:FIXed</code> | 76 |
| <code>[:SOURce<hw>]:BB:WLNN:TRIGger:OUTPut<ch>:DELay</code> | 76 |
| <code>[:SOURce<hw>]:BB:WLNN:TRIGger:OUTPut<ch>:DELay:MAXimum</code> | 77 |
| <code>[:SOURce<hw>]:BB:WLNN:TRIGger:OUTPut<ch>:DELay:MINimum</code> | 77 |
| <code>[:SOURce<hw>]:BB:WLNN:TRIGger:OUTPut<ch>:MODE</code> | 78 |
| <code>[:SOURce<hw>]:BB:WLNN:TRIGger:OUTPut<ch>:ONTime</code> | 78 |
| <code>[:SOURce<hw>]:BB:WLNN:TRIGger:OUTPut<ch>:OFFTime</code> | 79 |
| <code>[:SOURce<hw>]:BB:WLNN:TRIGger:OUTPut<ch>:FBINdex</code> | 79 |
| <code>[:SOURce<hw>]:BB:WLNN:TRIGger:OUTPut<ch>:FINdex</code> | 79 |
| <code>[:SOURce<hw>]:BB:WLNN:TRIGger:OUTPut<ch>:PATTern</code> | 80 |
| <code>[:SOURce<hw>]:BB:WLNN:TRIGger:OUTPut<ch>:PULSe:DIVider</code> | 80 |
| <code>[:SOURce<hw>]:BB:WLNN:TRIGger:OUTPut<ch>:PULSe:FREQuency</code> | 80 |

`[:SOURce<hw>]:BB:WLNN:TRIGger:OUTPut:DELay:FIXed` <Fixed>

The command restricts the marker delay setting range to the dynamic range. In this range the delay can be set without restarting the marker and signal. If a delay is entered in setting ON but is outside this range, the maximum possible delay is set and an error message is generated.

Parameters:

<Fixed> 0|1|OFF|ON

*RST: OFF

Example:

```
BB:WLNN:TRIG:OUTP:DEL:FIX ON
restricts the marker signal delay setting range to the dynamic
range.
```

`[:SOURce<hw>]:BB:WLNN:TRIGger:OUTPut<ch>:DELay` <Delay>

The command defines the delay between the signal on the marker outputs and the start of the signal, expressed in terms of samples. Command `:BB:WLNN:TRIGger:OUTPut:DELay:FIXed` can be used to restrict the range of values to the dynamic range, i.e. the range within which a delay of the marker signals can be set without restarting the marker and signal.

Parameters:

<Delay> float
 Range: 0 samples to $2^{32}-1$ samples
 Increment: 1 sample
 *RST: 0 samples

Example:

BB:WLNN:TRIG:OUTP2:DEL 1600
 sets a delay of 1600 samples for the signal on connector MARKER 2.

[[:SOURce<hw>]:BB:WLNN:TRIGger:OUTPut<ch>:DELay:MAXimum?

The command queries the maximum marker delay for setting :BB:WLNN:TRIG:OUTP:DEL:FIX ON.

Return values:

<Maximum> float

Example:

BB:WLNN:TRIG:OUTP:DEL:FIX ON
 restricts the marker signal delay setting range to the dynamic range.
 BB:WLNN:TRIG:OUTP:DEL:MAX
 queries the maximum of the dynamic range.
 Response: 2000
 the maximum for the marker delay setting is 2000 samples.

Usage: Query only

[[:SOURce<hw>]:BB:WLNN:TRIGger:OUTPut<ch>:DELay:MINimum?

The command queries the minimum marker delay for setting :BB:WLNN:TRIGger:OUTPut:DELay:FIXed ON.

Return values:

<Minimum> float

Example:

BB:WLNN:TRIG:OUTP:DEL:FIX ON
 restricts the marker signal delay setting range to the dynamic range.
 BB:WLNN:TRIG:OUTP:DEL:MIN
 queries the minimum of the dynamic range.
 Response: 0
 the minimum for the marker delay setting is 0 samples.

Usage: Query only

```
[:SOURce<hw>]:BB:WLNN:TRIGger:OUTPut<ch>:MODE <Mode>
```

Parameters:

<Mode>

REStart|FBLoCk|FRAMe|FAPart|PULSe|PATTern|RATio|
TRIGger

REStart

A marker signal is generated at the start of each signal sequence (period = all frame blocks).

FRAMe

Number of Frame Blocks = 1, that is, a marker signal is generated at the start of each frame in the single frame block. Otherwise, the frame block and frame index are entered and the specific frame is masked.

FBLoCk

Number of Frame Blocks = 1, that is, a marker signal is generated at the start of each frame block. Otherwise, a specific frame block index is given and the whole frame block is marked.

FAPart

Number of Frame Blocks = 1, that is, a marker signal is generated to mark every active part of each frame.

The active data transfer part (PPDU) of a frame period is marked with high, the inactive part (idle time) with low. This marker can be used to decrease the carrier leakage during inactive signal parts by feeding it into the pulse modulator.

Otherwise, the frame block and frame index are entered and the active part of the specific frame is masked.

PATTern

A marker signal is generated according to the user defined pattern (command `SOURce:BB:WLNN:TRIGger:OUTPut:PATTern`).

PULSe

A pulsed marker signal is generated. The pulse frequency (= symbol rate/divider) is defined with the

`SOUR:BB:WLNN:TRIG:OUTP:PULSe:DIVider` command and can be queried with the

`SOUR:BB:WLNN:TRIG:OUTP:PULSe:FREQuency?` command.

RATio

A marker signal corresponding to the Time Off / Time On specifications in the commands

`SOURce:BB:WLNN:TRIGger:OUTPut:OFFT` and

"`SOURce:BB:WLNN:TRIGger:OUTPut:ONT`" is generated.

*RST: REStart

Example:

```
BB:WLNN:TRIG:OUTP2:MODE FRAM
```

selects the frame marker signal on output MARKER 2.

```
[:SOURce<hw>]:BB:WLNN:TRIGger:OUTPut<ch>:ONTIME <Ontime>
```

[[:SOURce<hw>]:BB:WLNN:TRIGger:OUTPut<ch>:OFFTime <Offtime>

The command sets the number of samples in a period (ON time + OFF time) during which the marker signal in setting `SOURce:BB:WLNN:TRIGger:OUTPut:MODE RATio` on the marker outputs is OFF.

Parameters:

<Offtime> float

Range: 1 sample to 2²⁴-1 samples
 Increment: 1 sample
 *RST: 1 sample

Example:

`BB:WLNN:TRIG:OUTP2:OFFT 200`
 sets an OFF time of 200 samples for marker signal 2.

[[:SOURce<hw>]:BB:WLNN:TRIGger:OUTPut<ch>:FBINdex <Fbindex>

The command sets the frame block index. For this/these frame block(s), a marker signal is generated. The maximum value depends on the number of the currently active frame blocks (max = 100).

Parameters:

<Fbindex> float

Range: 0 to 100
 Increment: 1
 *RST: 1

Example:

`BB:WLNN:TRIG:OUTP1:FBIN 5`
 sets the frame block index to 5.

[[:SOURce<hw>]:BB:WLNN:TRIGger:OUTPut<ch>:FINdex <Findex>

The command sets the frame index, that is, the frame to be marked in the frame block marked with command `BB:WLNN:TRIGger:OUTPut:FBIndex`. The maximum value depends on the number of frames set with command `BB:WLNN:FBLOCK:FCOUNT`. The maximum value is 1024.

Parameters:

<Findex> float

Range: 1 to 1024
 Increment: 1

Example:

`BB:WLNN:TRIG:OUTP1:FIND 100`
 sets the frame index to 100.

[:SOURce<hw>]:BB:WLNN:TRIGger:OUTPut<ch>:PATTern <Pattern>

The command defines the bit pattern used to generate the marker signal in the setting `SOURce:BB:WLNN:TRIGger:OUTPut:MODE PATTern`.

0 is marker off

1 is marker on

Parameters:

<Pattern> integer

Range: #B0,1 to #B111...1, 32
*RST: #B0,1

Example:

`BB:WLNN:TRIG:OUTP2:PATT #B000000011111111,15`
sets a bit pattern.
`BB:WLNN:TRIG:OUTP2:MODE PATT`
activates the marker signal according to a bit pattern on output MARKER 2.

[:SOURce<hw>]:BB:WLNN:TRIGger:OUTPut<ch>:PULSe:DIVider <Divider>

The command sets the divider for Pulse marker mode (`SOUR:BB:WLNN:TRIG:OUTP:MODE PULSe`). The resulting pulse frequency is derived by dividing the symbol rate by the divider.

Parameters:

<Divider> float

Range: 2 to 1024
Increment: 1
*RST: 2

Example:

`BB:WLNN:TRIG:OUTP2:PULS:DIV 2`
sets the divider to 2 for the marker signal on output MARKER 2.
`BB:WLNN:TRIG:OUTP2:FREQ?`
queries the resulting pulse frequency of the marker signal.
Response: 66 000
the resulting pulse frequency is 66 kHz.

[:SOURce<hw>]:BB:WLNN:TRIGger:OUTPut<ch>:PULSe:FREQuency?

The command queries the pulse frequency of the pulsed marker signal in the setting `SOURce:BB:WLNN:TRIGger:OUTPut:MODE PULSe`. The pulse frequency is derived by dividing the symbol rate by the divider.

Return values:

<Frequency> float

Example: `BB:WLNN:TRIG:OUTP2:PULS:DIV 2`
 sets the divider marker signal on output MARKER 2 to the value 2.
`BB:WLNN:TRIG:OUTP2:MODE PULS`
 enables the pulsed marker signal.
`BB:WLNN:TRIG:OUTP2:PULS:FREQ?`
 queries the pulse frequency of the marker signal.
 Response: 33 000
 the resulting pulse frequency is 33 kHz.

Usage: Query only

4.5 Clock Settings

This section lists the remote control commands, necessary to configure the clock.



The clock settings are available for R&S SMx and R&S AMU instruments only.

| | |
|--|----|
| <code>[:SOURce<hw>]:BB:WLNN:CLOCK:MODE</code> | 81 |
| <code>[:SOURce<hw>]:BB:WLNN:CLOCK:MULTiplier</code> | 82 |
| <code>[:SOURce<hw>]:BB:WLNN:CLOCK:SOURce</code> | 82 |
| <code>[:SOURce<hw>]:BB:WLNN:CLOCK:SYNChronization:EXECute</code> | 83 |
| <code>[:SOURce<hw>]:BB:WLNN:CLOCK:SYNChronization:MODE</code> | 83 |

`[:SOURce<hw>]:BB:WLNN:CLOCK:MODE <Mode>`

The command enters the type of externally supplied clock (`:BB:WLNN:CLOCK:SOURce EXTERNAL`).

When `MSAMPLE` is used, a multiple of the sample clock is supplied via the `CLOCK` connector and the sample is derived internally from this. The multiplier is entered with the command `:BB:WLNN:CLOCK:MULTiplier`.

For two-path instruments, the only numerical suffix allowed for `SOURce` is 1, since the external clock source is permanently allocated to path A.

Parameters:

`<Mode>` `SAMPLE|MSAMPLE`

*RST: `SAMPLE`

Example: `BB:WLNN:CLOCK:MODE SAMP`
 selects clock type "Sample", i.e. the supplied clock is a sample clock.

[:SOURce<hw>]:BB:WLNN:CLOCK:MULTIplier <Multiplier>

Note: This command is available for clock source "External" and in clock mode "Multiple Sample" only. For two path instruments the Multiple Sample mode is currently available for path A only.

The command specifies the multiplier for clock type "Multiplied" (:BB:WLNN:CLOCK:MODE MSAMple) in the case of an external clock source.

For two-path instruments, the only numerical suffix allowed for SOURce is 1, since the external clock source is permanently allocated to path A.

Parameters:

| | |
|--------------|---------|
| <Multiplier> | float |
| Range: | 1 to 64 |
| Increment: | 1 |
| *RST: | 4 |

Example:

```
BB:WLNN:CLOC:SOUR EXT
selects the external clock source. The clock is supplied via the
CLOCK connector.
BB:WLNN:CLOC:MODE MSAM
selects clock type "Multiplied", i.e. the supplied clock has a rate
which is a multiple of the sample rate.
BB:WLNN:CLOC:MULT 12
the multiplier for the external clock rate is 12.
```

[:SOURce<hw>]:BB:WLNN:CLOCK:SOURce <Source>

The command selects the clock source.

For two-path instruments, selecting EXTERNAL is only possible for path A, since the external clock source is permanently allocated to path A; selecting AINTERNAL is only possible for path B.

Parameters:

| | |
|----------|-----------------------------|
| <Source> | INTERNAL EXTERNAL AINTERNAL |
|----------|-----------------------------|

INTERNAL

The internal clock reference is used.

EXTERNAL

The external clock reference is supplied to the CLOCK connector.

| | |
|-------|----------|
| *RST: | INTERNAL |
|-------|----------|

Example:

```
BB:WLNN:CLOC:SOUR EXT
selects an external clock reference. The clock is supplied via the
CLOCK connector.
BB:WLNN:CLOC:MODE SAMP
specifies that a sample clock is supplied via the CLOCK connector.
```

[:SOURce<hw>]:BB:WLNN:CLOCK:SYNChronization:EXECute

Performs automatically adjustment of the instrument's settings required for the synchronization mode, set with the command BB:WLNN:CLOC:SYNC:MODE.

Example: BB:WLNN:CLOC:SYNC:MODE MAST
the instrument is configured to work as a master one.
BB:WLNN:CLOC:SYNC:EXEC
all synchronization's settings are adjusted accordingly.

Usage: Event

[:SOURce<hw>]:BB:WLNN:CLOCK:SYNChronization:MODE <Mode>

Selects the synchronization mode.

This parameter is used to enable generation of very precise synchronous signal of several connected R&S SMBVs.

Note: If several instruments are connected, the connecting cables from the master instrument to the slave one and between each two consecutive slave instruments must have the same length and type. Avoid unnecessary cable length and branching points.

Parameters:

<Mode> NONE|MASTer|SLAVe

NONE

The instrument is working in stand-alone mode.

MASTer

The instrument provides all connected instrument with its synchronization (including the trigger signal) and reference clock signal.

SLAVe

The instrument receives the synchronization and reference clock signal from another instrument working in a master mode.

*RST: NONE

Example: BB:WLNN:CLOC:SYNC:MODE MAST
the instrument is configured to work as a master one.

4.6 Frame Configuration

FBLock<ch>

Value Range <ch> = [1] .. 100

| | |
|---|----|
| [:SOURce<hw>]:BB:WLNN:ANTenna:MODE..... | 85 |
| [:SOURce<hw>]:BB:WLNN:ANTenna:SYSTem..... | 85 |
| [:SOURce<hw>]:BB:WLNN:ANTenna:TCHain<ch>:OUTPut:DESTination..... | 86 |
| [:SOURce<hw>]:BB:WLNN:ANTenna:TCHain<ch>:OUTPut:FSElect..... | 86 |

| | |
|---|----|
| [SOURce<hw>]:BB:WLNN:ANTenna:TCHain<ch>:TX<dir>:PHASe..... | 87 |
| [SOURce<hw>]:BB:WLNN:ANTenna:TCHain<ch>:TX<dir>:IMAGinary..... | 87 |
| [SOURce<hw>]:BB:WLNN:ANTenna:TCHain<ch>:TX<dir>:MAGNitude..... | 87 |
| [SOURce<hw>]:BB:WLNN:ANTenna:TCHain<ch>:TX<dir>:REAL..... | 87 |
| [SOURce<hw>]:BB:WLNN:FBLOCK<ch>:BOOST..... | 88 |
| [SOURce<hw>]:BB:WLNN:FBLOCK<ch>:CODing:ENCoder..... | 88 |
| [SOURce<hw>]:BB:WLNN:FBLOCK<ch>:CODing:RATE..... | 88 |
| [SOURce<hw>]:BB:WLNN:FBLOCK<ch>:CODing:TYPE..... | 88 |
| [SOURce<hw>]:BB:WLNN:FBLOCK<ch>:COPY..... | 89 |
| [SOURce<hw>]:BB:WLNN:FBLOCK<ch>:DATA..... | 89 |
| [SOURce<hw>]:BB:WLNN:FBLOCK<ch>:DATA:BPSymbol..... | 89 |
| [SOURce<hw>]:BB:WLNN:FBLOCK<ch>:DATA:DSElection..... | 90 |
| [SOURce<hw>]:BB:WLNN:FBLOCK<ch>:DATA:LENGTh..... | 90 |
| [SOURce<hw>]:BB:WLNN:FBLOCK<ch>:DATA:PATTErn..... | 90 |
| [SOURce<hw>]:BB:WLNN:FBLOCK<ch>:DATA:RATE..... | 91 |
| [SOURce<hw>]:BB:WLNN:FBLOCK<ch>:DATA:SYMBols..... | 91 |
| [SOURce<hw>]:BB:WLNN:FBLOCK<ch>:DELeTe..... | 91 |
| [SOURce<hw>]:BB:WLNN:FBLOCK<ch>:ESSTream..... | 91 |
| [SOURce<hw>]:BB:WLNN:FBLOCK<ch>:FCOunt..... | 92 |
| [SOURce<hw>]:BB:WLNN:FBLOCK<ch>:GUARd..... | 92 |
| [SOURce<hw>]:BB:WLNN:FBLOCK<ch>:ILEaver:STATe..... | 92 |
| [SOURce<hw>]:BB:WLNN:FBLOCK<ch>:INSert..... | 92 |
| [SOURce<hw>]:BB:WLNN:FBLOCK<ch>:ITIme..... | 93 |
| [SOURce<hw>]:BB:WLNN:FBLOCK<ch>:MAC:ADDRess<st>..... | 93 |
| [SOURce<hw>]:BB:WLNN:FBLOCK<ch>:MAC:ADDRess<st>:STATe..... | 93 |
| [SOURce<hw>]:BB:WLNN:FBLOCK<ch>:MAC:DID..... | 94 |
| [SOURce<hw>]:BB:WLNN:FBLOCK<ch>:MAC:FCONTrol..... | 94 |
| [SOURce<hw>]:BB:WLNN:FBLOCK<ch>:MAC:FCONTrol:FDS..... | 94 |
| [SOURce<hw>]:BB:WLNN:FBLOCK<ch>:MAC:FCONTrol:MDATa..... | 94 |
| [SOURce<hw>]:BB:WLNN:FBLOCK<ch>:MAC:FCONTrol:MFRagments..... | 94 |
| [SOURce<hw>]:BB:WLNN:FBLOCK<ch>:MAC:FCONTrol:ORDER..... | 94 |
| [SOURce<hw>]:BB:WLNN:FBLOCK<ch>:MAC:FCONTrol:PMAManagement..... | 95 |
| [SOURce<hw>]:BB:WLNN:FBLOCK<ch>:MAC:FCONTrol:PVERsion..... | 95 |
| [SOURce<hw>]:BB:WLNN:FBLOCK<ch>:MAC:FCONTrol:RETRy..... | 95 |
| [SOURce<hw>]:BB:WLNN:FBLOCK<ch>:MAC:FCONTrol:SUBType..... | 95 |
| [SOURce<hw>]:BB:WLNN:FBLOCK<ch>:MAC:FCONTrol:TDS..... | 95 |
| [SOURce<hw>]:BB:WLNN:FBLOCK<ch>:MAC:FCONTrol:TYPE..... | 95 |
| [SOURce<hw>]:BB:WLNN:FBLOCK<ch>:MAC:FCONTrol:WEP..... | 95 |
| [SOURce<hw>]:BB:WLNN:FBLOCK<ch>:MAC:FCS:STATe..... | 95 |
| [SOURce<hw>]:BB:WLNN:FBLOCK<ch>:MAC:HTControl..... | 96 |
| [SOURce<hw>]:BB:WLNN:FBLOCK<ch>:MAC:HTControl:ACConstraint..... | 96 |
| [SOURce<hw>]:BB:WLNN:FBLOCK<ch>:MAC:HTControl:CALibration:POSition..... | 96 |
| [SOURce<hw>]:BB:WLNN:FBLOCK<ch>:MAC:HTControl:CALibration:SEQuence..... | 97 |
| [SOURce<hw>]:BB:WLNN:FBLOCK<ch>:MAC:HTControl:CSISteering..... | 97 |
| [SOURce<hw>]:BB:WLNN:FBLOCK<ch>:MAC:HTControl:FREQuest..... | 97 |
| [SOURce<hw>]:BB:WLNN:FBLOCK<ch>:MAC:HTControl:LAControl..... | 98 |
| [SOURce<hw>]:BB:WLNN:FBLOCK<ch>:MAC:HTControl:RDGMore..... | 98 |
| [SOURce<hw>]:BB:WLNN:FBLOCK<ch>:MAC:HTControl:REServed..... | 99 |
| [SOURce<hw>]:BB:WLNN:FBLOCK<ch>:MAC:HTControl:STATe..... | 99 |
| [SOURce<hw>]:BB:WLNN:FBLOCK<ch>:MAC:HTControl:ZLF..... | 99 |

| | |
|--|-----|
| <code>[SOURce<hw>]:BB:WLNN:FBLock<ch>:MAC:QSCONtrol</code> | 99 |
| <code>[SOURce<hw>]:BB:WLNN:FBLock<ch>:MAC:QSCONtrol:STATe</code> | 100 |
| <code>[SOURce<hw>]:BB:WLNN:FBLock<ch>:MAC:SCONtrol:FRAGment:INCRement</code> | 100 |
| <code>[SOURce<hw>]:BB:WLNN:FBLock<ch>:MAC:SCONtrol:FRAGment:START</code> | 100 |
| <code>[SOURce<hw>]:BB:WLNN:FBLock<ch>:MAC:SCONtrol:SEQUence:INCRement</code> | 101 |
| <code>[SOURce<hw>]:BB:WLNN:FBLock<ch>:MAC:SCONtrol:SEQUence:START</code> | 101 |
| <code>[SOURce<hw>]:BB:WLNN:FBLock<ch>:MAC:SCONtrol:STATe</code> | 101 |
| <code>[SOURce<hw>]:BB:WLNN:FBLock<ch>:MAC:STATe</code> | 101 |
| <code>[SOURce<hw>]:BB:WLNN:FBLock<ch>:MODulation<st></code> | 102 |
| <code>[SOURce<hw>]:BB:WLNN:FBLock<ch>:PASTe</code> | 102 |
| <code>[SOURce<hw>]:BB:WLNN:FBLock<ch>:PLCP:FORMat</code> | 102 |
| <code>[SOURce<hw>]:BB:WLNN:FBLock<ch>:PLCP:LCBit:STATe</code> | 102 |
| <code>[SOURce<hw>]:BB:WLNN:FBLock<ch>:PMODE</code> | 103 |
| <code>[SOURce<hw>]:BB:WLNN:FBLock<ch>:PREamble:STATe</code> | 103 |
| <code>[SOURce<hw>]:BB:WLNN:FBLock<ch>:PSDU:BRATe</code> | 103 |
| <code>[SOURce<hw>]:BB:WLNN:FBLock<ch>:PSDU:BSPReading:STATe</code> | 104 |
| <code>[SOURce<hw>]:BB:WLNN:FBLock<ch>:SCRambler:MODE</code> | 104 |
| <code>[SOURce<hw>]:BB:WLNN:FBLock<ch>:SCRambler:PATtern</code> | 105 |
| <code>[SOURce<hw>]:BB:WLNN:FBLock<ch>:SERVice:PATtern</code> | 105 |
| <code>[SOURce<hw>]:BB:WLNN:FBLock<ch>:SMAPping:BSElection</code> | 106 |
| <code>[SOURce<hw>]:BB:WLNN:FBLock<ch>:SMAPping:INDEX</code> | 106 |
| <code>[SOURce<hw>]:BB:WLNN:FBLock<ch>:SMAPping:MODE</code> | 106 |
| <code>[SOURce<hw>]:BB:WLNN:FBLock<ch>:SMAPping:ROW<st>:COL<dir>:I</code> | 107 |
| <code>[SOURce<hw>]:BB:WLNN:FBLock<ch>:SMAPping:ROW<st>:COL<dir>:Q</code> | 108 |
| <code>[SOURce<hw>]:BB:WLNN:FBLock<ch>:SMAPping:TShif<st></code> | 108 |
| <code>[SOURce<hw>]:BB:WLNN:FBLock<ch>:SSTream</code> | 108 |
| <code>[SOURce<hw>]:BB:WLNN:FBLock<ch>:STATe</code> | 109 |
| <code>[SOURce<hw>]:BB:WLNN:FBLock<ch>:STBC:STATe</code> | 109 |
| <code>[SOURce<hw>]:BB:WLNN:FBLock<ch>:STStream</code> | 109 |
| <code>[SOURce<hw>]:BB:WLNN:FBLock<ch>:TDWindowing:STATe</code> | 110 |
| <code>[SOURce<hw>]:BB:WLNN:FBLock<ch>:TMODE</code> | 110 |
| <code>[SOURce<hw>]:BB:WLNN:FBLock<ch>:TTIME</code> | 110 |
| <code>[SOURce<hw>]:BB:WLNN:FBLock<ch>:TYPE</code> | 110 |

`[SOURce<hw>]:BB:WLNN:ANTenna:MODE <Mode>`

The command selects the number of transmit antennas to be used.

Parameters:

`<Mode>` A1|A2|A3|A4

 *RST: A1

Example:

`BB:WLNN:ANT:MODE A1`
one antenna is used for transmission.

`[SOURce<hw>]:BB:WLNN:ANTenna:SYSTEM <System>`

The command selects the coordinate system of the transmission chain matrix.

Parameters:

<System> CARTesian|CYLindrical
 *RST: CARTesian

Example:

BB:WLNN:ANT:SYST CART
 sets the coordinate system of the transmission chain matrix to Cartesian.

[:SOURce<hw>]:BB:WLNN:ANTenna:TCHain<ch>:OUTPut:DESTination
 <Destination>

The command selects the destination of the calculated IQ chains.

Suffix:

<ch> [1]...4

Parameters:

<Destination> OFF|BB|BB_B|FILE

OFF

No mapping takes place.

BB

The IQ chain is output to the baseband A. Exactly one output stream can be mapped as "Baseband A".

BB_B

The IQ chain is output to the baseband B. Exactly one output stream can be mapped as "Baseband B".

FILE

The IQ chain is saved in a file.

*RST: OFF (for antenna 2, 3, 4); Baseband (for antenna 1)

Example:

BB:WLNN:ANT:TCH1:OUTP:DEST BB
 the IQ chain is saved in a file.

[:SOURce<hw>]:BB:WLNN:ANTenna:TCHain<ch>:OUTPut:FSElect <Fselect>

The command saves the IQ chain in a file.

Suffix:

<ch> [1]...4

Parameters:

<Fselect> string

Example: BB:WLNN:ANT:TCH1:OUTP:FSEL
'<root>\files\wlnn_1.wv'
saves the IQ chain in the selected file.

Usage: Event

[:SOURce<hw>]:BB:WLNN:ANTenna:TCHain<ch>:TX<dir>:PHASe
[:SOURce<hw>]:BB:WLNN:ANTenna:TCHain<ch>:TX<dir>:IMAGinary
<Imaginary>

The command enters the value for the Imaginary coordinate.

Suffix:
<ch> [1]...4

<dir> [1]...4

Parameters:
<Imaginary> float
Range: -1000 to 1000
Increment: 0.01
*RST: 0

Example: BB:WLNN:ANT:TCH1:TX2:IMAG 500
sets the imaginary coordinate for the selected transmission chain to 500.

[:SOURce<hw>]:BB:WLNN:ANTenna:TCHain<ch>:TX<dir>:MAGNitude
[:SOURce<hw>]:BB:WLNN:ANTenna:TCHain<ch>:TX<dir>:REAL <Real>

The command enters the value for the Real coordinate.

Suffix:
<ch> [1]...4

<dir> [1]...4

Parameters:
<Real> float
Range: -1000 to 1000
*RST: 0

Example: BB:WLNN:ANT:TCH1:TX2:REAL 500
sets the real coordinate for the selected transmission chain to 500.

[:SOURce<hw>]:BB:WLNN:FBLock<ch>:BOOST <Boost>

The command assigns a specific RMS power boost/attenuation to the corresponding Frame Block Modulation.

The power level of a Frame Block Modulation is calculated as sum of the power boost and the power level set in the header of the instrument.

Note: At least one Frame Block should have a power boost set to 0 dB value for this gated power mode functionality to work properly.

Parameters:

<Boost> float
 Range: -80 dB to 0 dB
 *RST: 0 dB

Example: BB:WLNN:FBL5:BOOS -10.0
 sets the power boost

[:SOURce<hw>]:BB:WLNN:FBLock<ch>:CODing:ENCoder?

The command queries the number of encoders to be used. This value depends on the data rate. For data rate \leq 300 Mps, this value is 1. Otherwise the number of encoders is 2.

Return values:

<Encoder> E1|E2

Example: BB:WLNN:FBL5:COD:ENC?
 queries the number of encoders to be used.

Usage: Query only

[:SOURce<hw>]:BB:WLNN:FBLock<ch>:CODing:RATE <Rate>

This command selects the coding rate.

Parameters:

<Rate> CR1D2|CR2D3|CR3D4|CR5D6
 *RST: CR_1D2

Example: BB:WLNN:FBL5:COD:RATE CR1D2
 sets the selected coding rate.

[:SOURce<hw>]:BB:WLNN:FBLock<ch>:CODing:TYPE <Type>

The command selects whether channel coding (BCC) is used or not.

Parameters:

<Type> OFF|BCC
 *RST: BCC

Example:

BB:WLNN:FBL5:COD:TYPE OFF
 no channel coding is used.

[:SOURce<hw>]:BB:WLNN:FBLock<ch>:COPY

Usage: Event

[:SOURce<hw>]:BB:WLNN:FBLock<ch>:DATA <Data>

This command selects the data source.

Parameters:

<Data> ZERO|ONE|PATTern|PN9|PN11|PN15|PN16|PN20|PN21|PN23|DLISt

PNxx

The pseudo-random sequence generator is used as the data source. Different random sequence lengths can be selected.

DLISt

A data list is used. The data list is selected with the command
 BB:WLNN:FBLocks:DATA:DSEL

ZERO | ONE

Internal 0 and 1 data is used.

PATTern

Internal data is used The bit pattern for the data is defined by the command
 BB:WLNN:FBLocks:DATA:PATTern.

*RST: PN9

Example:

BB:WLNN:FBL5:DATA PN9
 sets PN9 as the data source.

[:SOURce<hw>]:BB:WLNN:FBLock<ch>:DATA:BPSymbol?

The command queries the number of data bits sent by an OFDM symbol on all spatial streams.

Return values:

<Bpsymbol> float

Example:

BB:WLNN:FBL5:DATA:BPS?
 queries the number of data bits sent by an OFDM symbol on all spatial streams.

Usage: Query only

[:SOURCE<hw>]:BB:WLNN:FBLock<ch>:DATA:DSELECTION <Dselection>

The command selects the data list for the DLIS data source selection.

The lists are stored as files with the fixed file extensions *.dm_iqd in a directory of the user's choice. The directory applicable to the following commands is defined with the command `MEMORY:CDIR`. To access the files in this directory, you only have to give the file name without the path and the file extension.

Parameters:

<Dselection> string

Example:

```
BB:WLNN:FBL5:DATA DLIS
selects the Data Lists data source.
MEMORY:CDIR '<root>\Lists\DM\IqData'
selects the directory for the data lists.
BB:WLNN:FBL5:DATA:DSEL 'dlist1'
selects file 'dlist1' as the data source. This file must be in the
directory <root>\Lists\DM\IqData and have the file exten-
sion *.dm_iqd.
```

[:SOURCE<hw>]:BB:WLNN:FBLock<ch>:DATA:LENGTH <Length>

The command enters the size of the data field in bytes.

For Data Length = 0, no data field will be generated for the case of a sounding frame.

The maximum data length depends on the physical mode: In LEGACY mode, the maximum value is 4061 Bytes. In MIXED MODE and GREEN FIELD, the maximum value is 65495 Bytes.

The data length is related to the number of data symbols. Whenever the data length changes, the number of data symbols is updated and vice versa.

Parameters:

<Length> integer

Range: 0 to 4095

*RST: 1024 (for LEGACY); 65495 (for GREEN FIELD or MIXED MODE)

Example:

```
BB:WLNN:FBL5:DATA:LENG 500
sets the data length to 500 Bytes.
```

[:SOURCE<hw>]:BB:WLNN:FBLock<ch>:DATA:PATTERN <Pattern>

The command determines the bit pattern for the PATTERN selection. The maximum length is 64 bits.

Parameters:

<Pattern> integer

Example:

BB:WLNN:FBL5:DATA:PATT #H3F,8
sets the bit pattern.

[[:SOURce<hw>]:BB:WLNN:FBLock<ch>:DATA:RATE?

The command queries the PPDU data rate.

Return values:

<Rate> float

Example:

BB:WLNN:FBL5:DATA:RATE?
queries the data rate.

Usage:

Query only

[[:SOURce<hw>]:BB:WLNN:FBLock<ch>:DATA:SYMBOLs <Symbols>

The command sets the number of data symbols per frame block.

If the number of OFDM data symbols is changed, the generator calculates the data field length as a function of the set PPDU bit rate and displays it at Data Length.

Parameters:

<Symbols> float

Range: 1 to Max

Example:

BB:WLNN:FBL5:DATA:SYMB 1
sets the number of data symbols per frame block to 1.

[[:SOURce<hw>]:BB:WLNN:FBLock<ch>:DELEte

Usage: Event

[[:SOURce<hw>]:BB:WLNN:FBLock<ch>:ESSTream <Esstream>

The command enters the value of the extended spatial streams. This field is active for frame block type SOUNDING only to probe additional dimensions to the channel.

Parameters:

<Esstream> float

Range: 1 to 4

Increment: 1

*RST: 1

Example: `BB:WLNN:FBL5:ESSTR 4`
sets the number of the extended spatial streams to 4.

[:SOURce<hw>]:BB:WLNN:FBLock<ch>:FCOunt <Fcount>

The command sets the number of frames to be transmitted in the current frame block.

Parameters:

<Fcount> float
Range: 1 to 1024
Increment: 1
*RST: 1

Example: `BB:WLNN:FBL5:FCO 1`
sets the number of transmitted frames in the current frame block to 1.

[:SOURce<hw>]:BB:WLNN:FBLock<ch>:GUARd <Guard>

The command selects whether a long or short guard interval is used for the OFDM guard. In physical mode GREEN FIELD or LEGACY, only long guard intervals are possible. In this case, the field is read-only.

Parameters:

<Guard> SHORT|LONG
*RST: LONG

Example: `BB:WLNN:FBL5:GUAR LONG`
sets a long guard interval.

[:SOURce<hw>]:BB:WLNN:FBLock<ch>:ILEaver:STATe <State>

The command activates/deactivates the interleaver of the data field.

Parameters:

<State> 0|1|OFF|ON
*RST: ON

Example: `BB:WLNN:FBL5:ILE:STAT ON`
activates the interleaver.

[:SOURce<hw>]:BB:WLNN:FBLock<ch>:INSert

The command adds a default frame block before the selected frame block.

Example: BB:WLNN:FB20:INS
inserts a default frame block before the selected frame block.

Usage: Event

[[:SOURce<hw>]:BB:WLNN:FBLOCK<ch>:ITIME <itime>

The command sets the time interval separating two frames in this frame block. The default unit for the time interval are seconds. However, the time interval can be set in milliseconds. In this case the unit has to be set.

The command sets the time interval separating two frames in this frame block. The default unit for the time interval are seconds. However, the time interval can be set in milliseconds. In this case the unit has to be set.

Parameters:

<itime> float
Range: 0 sec to 1.0 sec
Increment: 0.001 sec
*RST: 0 sec

Example: BB:WLNN:FBL5:ITIME 2.5ms
sets the idle time to 2.5 msec.

[[:SOURce<hw>]:BB:WLNN:FBLOCK<ch>:MAC:ADDRESS<st> <Address>

The command enters the value of the address fields 1 ... 4. Exactly 48 bits must be entered. Each address is 6 bytes (48 bit) long. The addresses can be entered in hexadecimal form in the entry field of each address field. The least significant byte (LSB) is in left notation.

Suffix:

<st> 1|2|3|4

Parameters:

<Address> integer
Range: #H000000000000,48 to #FFFFFFFFFFFFFF,48
*RST: #H000000000000,48

Example: BB:WLNN:FBL1:MAC:ADDR2 #H124836C7EA54,48
set the value for address field 2.

[[:SOURce<hw>]:BB:WLNN:FBLOCK<ch>:MAC:ADDRESS<st>:STATE <State>

The command activates/deactivates the selected address field.

Suffix:
<st> 1|2|3|4

Parameters:
<State> 0|1|OFF|ON
*RST: OFF

Example: BB:WLNN:FBL1:MAC:ADDR2:STAT ON
activates generation of address field 2.

[:SOURCE<hw>]:BB:WLNN:FBLOCK<ch>:MAC:DID <Did>

The command enters the value of the duration ID field. Depending on the frame type, the 2-byte field Duration/ID is used to transmit the association identity of the station transmitting the frame or it indicates the duration assigned to the frame type. Exactly 16 bit must be entered.

Parameters:
<Did> integer
Range: #H0000,16 to #HFFFF,16
*RST: #H0000,16

Example: BB:WLNN:FBL1:MAC:DID #HA5A5,16
sets the value of the duration ID field.

[:SOURCE<hw>]:BB:WLNN:FBLOCK<ch>:MAC:FCONTROL <Fcontrol>

The command enters the value of the frame control field. The frame control field has a length of 2 bytes (16 bits) and is used to define the protocol version, the frame type, and its function, etc.. As an alternative, the individual bits can be set with the following commands.

Parameters:
<Fcontrol> integer
Range: #H0000,16 to #HFFFF,16
*RST: #H0000,16

Example: BB:WLNN:FBL1:MAC:FCON #H100A,16
sets the value of the frame control field.

[:SOURCE<hw>]:BB:WLNN:FBLOCK<ch>:MAC:FCONTROL:FDS <Fds>
[:SOURCE<hw>]:BB:WLNN:FBLOCK<ch>:MAC:FCONTROL:MDATA <Mdata>
[:SOURCE<hw>]:BB:WLNN:FBLOCK<ch>:MAC:FCONTROL:MFRAGMENTS
 <Mfragments>
[:SOURCE<hw>]:BB:WLNN:FBLOCK<ch>:MAC:FCONTROL:ORDER <Order>

```

[:SOURce<hw>]:BB:WLNN:FBLock<ch>:MAC:FCONtrol:PMANagement
  <Pmanagement>
[:SOURce<hw>]:BB:WLNN:FBLock<ch>:MAC:FCONtrol:PVERsion <Pversion>
[:SOURce<hw>]:BB:WLNN:FBLock<ch>:MAC:FCONtrol:RETRY <Retry>
[:SOURce<hw>]:BB:WLNN:FBLock<ch>:MAC:FCONtrol:SUBType <Subtype>
[:SOURce<hw>]:BB:WLNN:FBLock<ch>:MAC:FCONtrol:TDS <Tds>
[:SOURce<hw>]:BB:WLNN:FBLock<ch>:MAC:FCONtrol:TYPE <Type>
[:SOURce<hw>]:BB:WLNN:FBLock<ch>:MAC:FCONtrol:WEP <Wep>

```

The command enters the value of the individual bits of the frame control field.

Parameters:

```

<Wep>                integer
                    Range:  #H0,1 to #H1,1
                    *RST:   #H0,1

<Fds>|<Mdata>|      integer
<Mfragments>|
<Order>|
<Pmanagement>|
<Pversion>|<Retr>|
<TDS>
                    Range:  #H0,1 to #H1,1
                    *RST:   #H0,1

<Subtype>           integer
                    Range:  #H0,4 to #HF,4
                    *RST:   #H0,1

<Type>              integer
                    Range:  #H0,2 to #H3,2
                    *RST:   #H0,1

```

Example: BB:WLNN:FBL1:MAC:FCON:MDAT #H1,1
sets the value of the More Data bit.

```

[:SOURce<hw>]:BB:WLNN:FBLock<ch>:MAC:FCS:STATe <State>

```

Activates/deactivates the calculation of the FCS (frame check sequence). The standard defines a 32-bit (4-byte) checksum to protect the MAC header and the user data (frame body).

Parameters:

```

<State>              0|1|OFF|ON
                    *RST:   OFF

```

Example: BB:WLNN:FBL1:MAC:FCS:STAT ON
activates the calculation of the FCS.

[:SOURCE<hw>]:BB:WLNN:FBLock<ch>:MAC:HTControl <Htcontrol>

The command sets the value for the HT control field.

Parameters:

<Htcontrol> integer

Range: #H0000,4 to #HFFFF,4

*RST: 0000 0000

Example: BB:WLNN:FBL1:MAC:HTC #H5a5a5a5a,4
sets the value for the HT control field.

**[:SOURCE<hw>]:BB:WLNN:FBLock<ch>:MAC:HTControl:ACConstraint
<Acconstraint>**

The command sets the value for the AC signal field.

0 = The response may contain data from any TID (Traffic Identifier).

1 = The response may contain data only from the same AC as the last Data received from the initiator.

Parameters:

<Acconstraint> integer

Range: #H0,1 to #H1,1

*RST: 0

Example: BB:WLNN:FBL1:MAC:HTC:ACC #H0,1
sets the AC signal field to 0 (The response may contain data from any TID)

**[:SOURCE<hw>]:BB:WLNN:FBLock<ch>:MAC:HTControl:CALibration:POSition
<Position>**

The command sets the value for the calibration position.

00 = Not a calibration frame (Default setting)

01 = Calibration Start

10 = Sounding Response

11 = Sounding Complete

Parameters:

<Position> integer

Range: #H0,2 to #H3,2

Example: BB:WLNN:FBL1:MAC:HTC:CAL:POS #H0,2
sets the Calibration Position signal field to 00 (Not a calibration frame).

[:SOURCE<hw>]:BB:WLNN:FBLock<ch>:MAC:HTControl:CALibration:SEQuence
 <Sequence>

The command sets the value for the calibration sequence.

Parameters:

<Sequence> integer
 Range: #H0,2 to #H3,2

Example: BB:WLNN:FBL1:MAC:HTC:CAL:SEQ #H3,2
 sets the value for the calibration sequence.

[:SOURCE<hw>]:BB:WLNN:FBLock<ch>:MAC:HTControl:CSISteering
 <Csisteering>

The command sets the value for the CSI steering.

00 = CSI
01 = uncompressed Steering Matrix
10 = compressed Steering Matrix
11 = Reserved

Parameters:

<Csisteering> integer
 Range: #H0,2 to #H3,2

Example: BB:WLNN:FBL1:MAC:HTC:CSIS #H1,2
 sets the value for the CSI steering to 01 (uncompressed Steering Matrix).

[:SOURCE<hw>]:BB:WLNN:FBLock<ch>:MAC:HTControl:FREQuest <Frequest>

The command sets the value for the feedback request.

00 = no request
01 = unsolicited feedback only
10 = immediate feedback
11 = aggregated feedback

Parameters:

<Frequest> integer
 Range: #H0,2 to #H3,2

Example: BB:WLNN:FBL1:MAC:HTC:FREQ #H2,2
 sets the value for the feedback request to 10 (immediate feedback).

[:SOURce<hw>]:BB:WLNN:FBLock<ch>:MAC:HTControl:LACControl <Lacontrol>

The command sets the value for the Link Adaption Control.

B0 (1bit) MA - MA payload

When the MA (Management Action) field is set to 1, the payload of the QoS Null Data MPDU (Medium Access Controller Protocol Data Unit) is interpreted as a payload of the management action frame.

B1 (1bit) TRQ - Sounding Request

1 = Request to the responder to transmit a sounding PPDU (Physical layer Protocol Data Unit).

B2 (1bit) MRQ - MCS Request

1 = Request for feedback of MCS (Modulation Coding Scheme).

B3-B5 (3bit) MRS - MRQ Sequence Identifier

Set by sender to any value in the range '000'-'110' to identify MRQ. = Invalid if MRQ = 0

B6-B8 (3bit) MFS - MFB Sequence Identifier

Set to the received value of MRS. Set to '111' for unsolicited MFB.

B9-B15 (7bit) MFB - MCS Feedback

Link adaptation feedback containing the recommended MCS. When a responder is unable to provide MCS feedback or the feedback is not available, the MFB is set to 'all-ones' (default value) and also MFS is set to '1'.

Parameters:

| | |
|-------------|-------------------------------|
| <Lacontrol> | integer |
| | Range: #H0000,16 to #HFFFF,16 |

Example: BB:WLNN:FBL1:MAC:HTC:LAC #H5A5A,16 sets the value for the Link AdaptionControl.

[:SOURce<hw>]:BB:WLNN:FBLock<ch>:MAC:HTControl:RDGMore <Rdgmores>

The command sets the value for the RDG/More PPDU.

Transmitted by Initiator

0 = No reverse grant.

1 = A reverse grant is present, as defined by the Duration/ID field.

Transmitted by Responder

0 = The PPDU carrying the MPDU is the last transmission by the responder.

1 = The PPDU carrying the MPDU is the last transmission by the responder.

Parameters:**<Rdgmore>** integer

Range: #H0,1 to #H1,1

Example:

```
BB:WLNN:FBL1:MAC:HTC:RDGM #H0,1
sets the value for the RDG/More PDU.
```

[:SOURCE<hw>]:BB:WLNN:FBLock<ch>:MAC:HTControl:REServed <Reserved>

This signal field is currently defined, but not used. It is set to zero by the transmitter and ignored by the receiver.

Parameters:**<Reserved>** integer

Range: #H0,5 to #H5,2

[:SOURCE<hw>]:BB:WLNN:FBLock<ch>:MAC:HTControl:STATE <State>

The command enables/disables HT Control.

Parameters:**<State>** 0|1|OFF|ON

*RST: OFF

Example:

```
BB:WLNN:FBL1:MAC:HTC:STAT ON
enables HT Control.
```

[:SOURCE<hw>]:BB:WLNN:FBLock<ch>:MAC:HTControl:ZLF <Zlf>

The command sets the value for the ZLF announcement.

0 = no ZLF will follow

1 = ZLF will follow

Parameters:**<Zlf>** integer

Range: #H0,1 to #H1,1

Example:

```
BB:WLNN:FBL1:MAC:HTC:ZLF #H1,1
sets the value for the ZLF announcement to 1 (ZLF will follow).
```

[:SOURCE<hw>]:BB:WLNN:FBLock<ch>:MAC:QSControl <Qscontrol>

The command sets the value for the QoS control field.

Parameters:

<Qscontrol> integer
 Range: #H0000,16 to #HFFFF,16

Example:

BB:WLNN:FBL1:MAC:QSC #H5A5A,16
 sets the value for the QoS field.

[:SOURCE<hw>]:BB:WLNN:FBLock<ch>:MAC:QSControl:STATe <State>

The command enables/disables the QoS control.

Parameters:

<State> 0|1|OFF|ON
 *RST: OFF

Example:

BB:WLNN:FBL1:MAC:QSC:STAT ON
 enables the QoS control.

[:SOURCE<hw>]:BB:WLNN:FBLock<ch>:MAC:SCONtrol:FRAGment:INCRement <Increment>

Defines the number of packets required to increment the counter of the fragment bits of the sequence control.

Parameters:

<Increment> float
 Range: 0 to 1024
 *RST: 1

Example:

BB:WLNN:FBL1:MAC:SCON:FRAG:INCR 2
 two packets are required to increment the counter of the fragment bits.

[:SOURCE<hw>]:BB:WLNN:FBLock<ch>:MAC:SCONtrol:FRAGment:STARt <Start>

The command enters the start number of the fragment bits of the sequence control.

Parameters:

<Start> integer
 Range: #H0,4 to #HF,4
 *RST: #H0,4

Example:

BB:WLNN:FBL1:MAC:SCON:FRAG:STAR #H4,4
 sets the start value of the fragment bits of the sequence control.

[:SOURce<hw>]:BB:WLNN:FBLock<ch>:MAC:SCONtrol:SEQuence:INCRement <Increment>

Defines the number of packets required to increment the counter of the sequence bits of the sequence control.

Parameters:

<Increment> float
 Range: 0 to 1024
 *RST: 1

Example:

BB:WLNN:FBL1:MAC:SCON:FRAG:INCR 2
 two packets are required to increment the counter of the sequence bits.

[:SOURce<hw>]:BB:WLNN:FBLock<ch>:MAC:SCONtrol:SEQuence:STARt <Start>

The command enters the start number of the fragment bits of the sequence control.

Parameters:

<Start> integer
 Range: #H0,4 to #HFFF,4
 *RST: #H0,4

Example:

BB:WLNN:FBL1:MAC:SCON:SEQ:STAR #H4,4
 sets the start value of the sequence bits of the sequence control.

[:SOURce<hw>]:BB:WLNN:FBLock<ch>:MAC:SCONtrol:STATe <State>

The command activates/deactivates the sequence control.

Parameters:

<State> 0|1|OFF|ON
 *RST: OFF

Example:

BB:WLNN:FBL1:MAC:SCON:STAT ON
 activates the sequence control field.

[:SOURce<hw>]:BB:WLNN:FBLock<ch>:MAC:STATe <State>

The command activates/deactivates the generation of the MAC Header.

Parameters:

<State> 0|1|OFF|ON
 *RST: OFF

Example: `BB:WLNN:FBL1:MAC:STAT ON`
activates the generation of the MAC Header.

[:SOURCE<hw>]:BB:WLNN:FBLock<ch>:MODulation<st> <Modulation>

The command selects the modulation used for the spatial stream.

Suffix:
<st> 1 .. 4

Parameters:
<Modulation> BPSK|QPSK|QAM16|QAM64

*RST: QPSK; BPSK for Tx Mode HT-Duplicate

Example: `BB:WLNN:FBL5:MOD1 BPSK`
sets BPSK as the modulation mode used for the spatial stream.

[:SOURCE<hw>]:BB:WLNN:FBLock<ch>:PASTe

Usage: Event

[:SOURCE<hw>]:BB:WLNN:FBLock<ch>:PLCP:FORMat <Format>

(available only for CCK and PBCC transport modes)

Selects the packet type (PPDU format) with long or short PLCP (physical layer convergence protocol).

Depending on the format selected, the structure, modulation and data rate of the PLCP preamble and header are modified.

Parameters:
<Format> LONG|SHORT

*RST: LONG

Example: `BB:WLNN:FBL5:PMod LEG`
sets the physical mode to LEGACY.
`BB:WLNN:FBL5:TMod CCK`
sets the transport mode
`BB:WLNN:FBL5:PLCP:FORM SHOR`
sets the PLCP Format

[:SOURCE<hw>]:BB:WLNN:FBLock<ch>:PLCP:LCBit:STATe <State>

(available only for CCK and PBCC transport modes)

Sets the Locked Clock Bit in Service Field of the PLCP Header.

Parameters:

<State> 0|1|OFF|ON
 *RST: ON

Example:

```
BB:WLNN:FBL5:PMOD LEG
sets the physical mode to LEGACY.
BB:WLNN:FBL5:TMOD CCK
sets the transport mode
BB:WLNN:FBL5:PLCP:LCB:STAT OFF
sets the Locked Clock Bit
```

[[:SOURCE<hw>]:BB:WLNN:FBLock<ch>:PMODE <Pmode>

Selects the preamble design.

For physical type SOUNDING, only GREEN FIELD is available.

Parameters:

<Pmode> LEGacy|MIXed|GFieId
LEGacy
 Compatible with 802.11 a/g OFDM devices.
MIXed
 For High Throughput (HT) and 802.11a/g OFDM devices.
GRFieId
 For HT only networks.
 *RST: MIXed

Example:

```
BB:WLNN:FBL5:PMOD LEG
sets the physical mode to LEGACY.
```

[[:SOURCE<hw>]:BB:WLNN:FBLock<ch>:PREamble:STATE <State>

The command activates/deactivates the preamble and signal fields of the frames in the current frame block. For data type = SOUNDING, the preamble and signal field are always activated and cannot be deactivated.

Parameters:

<State> 0|1|OFF|ON
 *RST: ON

Example:

```
BB:WLNN:FBL5:PRE:STAT ON
activates the preamble and signal fields of the frames in the current frame block.
```

[[:SOURCE<hw>]:BB:WLNN:FBLock<ch>:PSDU:BRATE <Brate>

(available only for CCK and PBCC transport modes)

Sets the PSDU bit rate.

Parameters:

<Brate> P1MBPS|P2MBPS|P5.5MBPS|P11MBPS|P22MBPS
 *RST: R11MBPS

Example:

```
BB:WLNN:FBL5:PMOD LEG
sets the physical mode to LEGACY.
BB:WLNN:FBL5:TMOD CCK
sets the transport mode
BB:WLNN:FBL5:PSDU:BRAT P2MBPS
sets the PSDU bit rate
```

[[:SOURCE<hw>]:BB:WLNN:FBLock<ch>:PSDU:BSPReading:STATE <State>

(available only for CCK and PBCC transport modes)

Enables/disables Barker spreading.

Parameters:

<State> 0|1|OFF|ON

Example:

```
BB:WLNN:FBL5:PMOD LEG
sets the physical mode to LEGACY.
BB:WLNN:FBL5:TMOD CCK
sets the transport mode
BB:WLNN:FBL5:PSDU:BRAT 2MBPS
sets the PSDU bit rate
BB:WLNN:FBL5:PSDU:BSPR:STAT ON
enables spreading
```

[[:SOURCE<hw>]:BB:WLNN:FBLock<ch>:SCRambler:MODE <Mode>

The command selects the different options for the scrambler.

Parameters:

<Mode>

OFF|RANDom|USER|ON|PREAmble

OFF

The scrambler is deactivated.

RANDom

(not for CCK/PBCC)

The scrambler is activated.

The initialization value of the scrambler is selected at random.

Each frame has a different random initialization value. This value is also different in case of successive recalculations with the same setting parameters so that different signals are generated for each calculation.

USER

(not for CCK/PBCC)

The scrambler is activated.

The initialization value of the scrambler is set to a fixed value that is set using the command BB:WLNN:FBL5:SCR:PATT. This value is then identical in each generated frame.

ON

(CCK/PBCC only)

The scrambler is activated.

PREAmble

(CCK/PBCC only)

The scrambler is activated. Only the preamble is scrambled.

*RST: RAND

Example:

BB:WLNN:FBL5:SCR:MODE RAND

activates the scrambler with an random initialization value.

[[:SOURCE<hw>]:BB:WLNN:FBLock<ch>:SCRambler:PATTern <Pattern>

The command sets the initialization value for scrambling mode User. This value is then identical in each generated frame.

Parameters:

<Pattern>

integer

Example:

BB:WLNN:FBL5:SCR:PATT #H3F,8

sets the user defined initialization value for the scrambler.

[[:SOURCE<hw>]:BB:WLNN:FBLock<ch>:SERVICE:PATTern <Pattern>

The command sets the value of the service field. The standard specifies a default value of 0. Other values can be entered in hexadecimal form for test purposes or future extensions.

Parameters:

<Pattern> integer

Example:

```
BB:WLNN:FBL5:SERV:PATT #H3F,8
```

sets the value for the service field.

[:SOURCE<hw>]:BB:WLNN:FBLock<ch>:SMAPping:BSElection <Bselection>

The command loads the selected file for beamforming.

Setting parameters:

<Bselection> string

Example:

```
BB:WLNN:FBL1:PMOD MIX
BB:WLNN:FBL1:SMAP:MODE BEAM
BB:WLNN:FBL1:SMAP:BSEL
'<root>\temp\test_sspi.bmf'
```

loads the selected file for beamforming.

Usage:

Setting only

[:SOURCE<hw>]:BB:WLNN:FBLock<ch>:SMAPping:INDEX <Index>

The command sets the index of the sub-carrier. A matrix is mapped to each sub-carrier. With the exception of k=0, the index can be set in the value range of -64 to 63

Parameters:

<Index> float

Range: -64 to 63

*RST: 20

Example:

```
BB:WLNN:FBL1:SMAP:IND 30
```

sets the index of the sub-carrier to k = 30.

[:SOURCE<hw>]:BB:WLNN:FBLock<ch>:SMAPping:MODE <Mode>

The command selects the spatial mapping mode for the selected frame block. Except of the Beamforming mode, the matrix element values are loaded through the use of Info Class Methods.

Parameters:

<Mode>

OFF|DIRect|EXPansion|BEAMforming

OFF

(only "LEGACY" mode)

The spatial mapping mode is switched off automatically.

DIRect(only active with physical modes MIXED MODE or GREEN FIELD when $N_{TX} = N_{STS}$)

Sets the spatial mapping to "Direct" mode.

The transmit matrix is a CSD matrix, that is, diagonal matrix of unit magnitude and complex values that represent cyclic shifts in the time domain.

EXPansion

(only active with physical modes MIXED MODE or GREEN FIELD)

Sets the spatial mapping to "Expansion" mode.

The transmit matrix is the product of a CSD matrix and the Hadamard unitary matrix.

BEAMforming

(this feature will be supported in further release)

Sets the spatial mapping to Beamforming mode.

The transmit matrix is the product of a CSD matrix and the Hadamard unitary matrix.

The File button is displayed to open a Browse popup. A file with source format *.bmf can be selected for the beamforming. The file must include 128 4*4 IQ elements (corresponding to the sub-carriers).

*RST: EXPansion

Example:

BB:WLNN:FBL1:SMAP:MODE OFF

sets the spatial mapping mode to OFF, that is, the spatial mapping mode is switched off automatically.

[[:SOURce<hw>]:BB:WLNN:FBLock<ch>:SMAPping:ROW<st>:COL<dir>:I?

The command queries the time shift value of element I of the selected row and column of the spatial transmit matrix.

Suffix:

<st> [1] .. 4

<dir> [1] .. 4

Return values:

<I> float

Example: BB:WLNN:FBL1:SMAP:ROW2:COL2:I?
queries the time shift value of element I for row 2, column 2.

Usage: Query only

[:SOURCE<hw>]:BB:WLNN:FBLock<ch>:SMAPping:ROW<st>:COL<dir>:Q?

The command queries the time shift value of element Q of the selected row and column of the spatial transmit matrix.

Suffix:
<st> [1] .. 4

<dir> [1] .. 4

Return values:
<Q> float

Example: BB:WLNN:FBL1:SMAP:ROW2:COL2:Q?
queries the time shift value of element Q for row 2, column 2.

Usage: Query only

[:SOURCE<hw>]:BB:WLNN:FBLock<ch>:SMAPping:TSHift<st> <Tshift>

The command sets the spatial mapping time shift. This value is relevant for spatial mapping mode Direct and Spatial Expansion only.

Suffix:
<st> [1] .. 4

Parameters:
<Tshift> float
Range: -32000 ns to 32000 ns
*RST: 0 ns

Example: BB:WLNN:FBL1:SMAP:MODE TSH 1000
sets the spatial mapping time shift to 1000 ns.

[:SOURCE<hw>]:BB:WLNN:FBLock<ch>:SSTReam <Sstream>

The command sets the number of the spatial streams. For physical mode LEGACY, only value 1 is valid. For Tx Mode "HT-Duplicate", only value 1 is valid. In all other cases, the number of spatial streams depends on the number of antennas configured with command SOURCE:BB:WLNN:ANTenna:MODE.

Parameters:

<Sstream> float
 Range: 1 to 4
 *RST: 1

Example:

BB:WLNN:FBL5:SSTR 4
 sets the number of spatial streams to 4.

[:SOURCE<hw>]:BB:WLNN:FBLock<ch>:STATe <State>

The command enables the corresponding frame block for transmission.

Parameters:

<State> 0|1|OFF|ON
 *RST: OFF

Example:

BB:WLNN:FBL5:STAT ON
 enables frame block 5 for transmission.

[:SOURCE<hw>]:BB:WLNN:FBLock<ch>:STBC:STATe?

The command queries the status of the space time block coding.

Return values:

<State> INACTIVE|ACTIVE

Example:

BB:WLNN:FBL5:STBC:STAT?
 queries the status of the space time block coding.

Usage:

Query only

[:SOURCE<hw>]:BB:WLNN:FBLock<ch>:STStream <Ststream>

The command sets the number of the space time streams. This value depends on the number of spatial streams defined with command

SOURCE:BB:WLNN:FBLock:SSTream. Changing the number of the Spatial Streams immediately changes the value of the Space Time Streams to the same value.

Parameters:

<Ststream> float
 Range: 1 to 4
 *RST: 1

Example:

BB:WLNN:FBL5:STBC:STAT?
 queries the status of the space time block coding.

[:SOURce<hw>]:BB:WLNN:FBLock<ch>:TDWindowing:STATe <State>

The command activates/deactivates the time domain windowing. Time domain windowing is a method to influence the spectral characteristics of the signal, which is not stipulated by the standard. However, it does not replace oversampling and subsequent signal filtering.

Parameters:

<State> 0|1|OFF|ON
 *RST: ON

Example:

BB:WLNN:FBL5:TDW:STAT ON
 activates the time domain windowing.

[:SOURce<hw>]:BB:WLNN:FBLock<ch>:TMODE <Tmode>

The command sets the Tx mode. The available Tx modes are dependent on the physical mode.

Parameters:

<Tmode> L20|LDUP|LUP|LLOW|CCK|PBCC|HT20|HT40|HTDup|HTUP|HTLow
 *RST: HT20

Example:

BB:WLNN:FBL5:TMOD HT40
 sets the Tx mode to HT 40 MHz.

[:SOURce<hw>]:BB:WLNN:FBLock<ch>:TTIME <Ttime>

The command sets the transition time when time domain windowing is active.

The transition time defines the overlap range of two OFDM symbols. At a setting of 100 ns and if BW = 20 MHz, one sample overlaps.

Parameters:

<Ttime> float
 Range: 0 ns to 1000 ns
 Increment: 1 ns
 *RST: 100 ns

Example:

BB:WLNN:FBL5:TTIM 100
 sets the transition time to 100 ns.

[:SOURce<hw>]:BB:WLNN:FBLock<ch>:TYPE <Type>

The command selects the PPDU type.

Parameters:

<Type>

DATA|SOUNDing

DATA

Only Data Long Training Fields are used to probe the channel.

SOUNDing

Staggered preambles are used to probe additional dimension of the MIMO channel. Only Physical Layer Mode GREEN FIELD is available.

*RST: DATA

Example:

```
BB:WLNN:FBL5:TYPE DATA
```

sets the PPDU type data.

List of Commands

| | |
|---|----|
| [SOURce<hw>]:BB:WLNN:ANTenna:MODE..... | 85 |
| [SOURce<hw>]:BB:WLNN:ANTenna:SYSTem..... | 85 |
| [SOURce<hw>]:BB:WLNN:ANTenna:TCHain<ch>:OUTPut:DESTination..... | 86 |
| [SOURce<hw>]:BB:WLNN:ANTenna:TCHain<ch>:OUTPut:FSElect..... | 86 |
| [SOURce<hw>]:BB:WLNN:ANTenna:TCHain<ch>:TX<dir>:IMAGinary..... | 87 |
| [SOURce<hw>]:BB:WLNN:ANTenna:TCHain<ch>:TX<dir>:MAGNitude..... | 87 |
| [SOURce<hw>]:BB:WLNN:ANTenna:TCHain<ch>:TX<dir>:PHASe..... | 87 |
| [SOURce<hw>]:BB:WLNN:ANTenna:TCHain<ch>:TX<dir>:REAL..... | 87 |
| [SOURce<hw>]:BB:WLNN:BWidth..... | 58 |
| [SOURce<hw>]:BB:WLNN:CFBLock..... | 59 |
| [SOURce<hw>]:BB:WLNN:CLIPping:LEVel..... | 64 |
| [SOURce<hw>]:BB:WLNN:CLIPping:MODE..... | 64 |
| [SOURce<hw>]:BB:WLNN:CLIPping:STATe..... | 64 |
| [SOURce<hw>]:BB:WLNN:CLOCK:MODE..... | 81 |
| [SOURce<hw>]:BB:WLNN:CLOCK:MULTiplier..... | 82 |
| [SOURce<hw>]:BB:WLNN:CLOCK:SOURce..... | 82 |
| [SOURce<hw>]:BB:WLNN:CLOCK:SYNChronization:EXECute..... | 83 |
| [SOURce<hw>]:BB:WLNN:CLOCK:SYNChronization:MODE..... | 83 |
| [SOURce<hw>]:BB:WLNN:DFBLock..... | 59 |
| [SOURce<hw>]:BB:WLNN:FBLock:APPend..... | 58 |
| [SOURce<hw>]:BB:WLNN:FBLock:APPend..... | 58 |
| [SOURce<hw>]:BB:WLNN:FBLock<ch>:BOOSt..... | 88 |
| [SOURce<hw>]:BB:WLNN:FBLock<ch>:CODing:ENCOder..... | 88 |
| [SOURce<hw>]:BB:WLNN:FBLock<ch>:CODing:RATE..... | 88 |
| [SOURce<hw>]:BB:WLNN:FBLock<ch>:CODing:TYPE..... | 88 |
| [SOURce<hw>]:BB:WLNN:FBLock<ch>:COPIY..... | 59 |
| [SOURce<hw>]:BB:WLNN:FBLock<ch>:COPIY..... | 89 |
| [SOURce<hw>]:BB:WLNN:FBLock<ch>:DATA..... | 89 |
| [SOURce<hw>]:BB:WLNN:FBLock<ch>:DATA:BPSymbol..... | 89 |
| [SOURce<hw>]:BB:WLNN:FBLock<ch>:DATA:DSElection..... | 90 |
| [SOURce<hw>]:BB:WLNN:FBLock<ch>:DATA:LENGTh..... | 90 |
| [SOURce<hw>]:BB:WLNN:FBLock<ch>:DATA:PATTern..... | 90 |
| [SOURce<hw>]:BB:WLNN:FBLock<ch>:DATA:RATE..... | 91 |
| [SOURce<hw>]:BB:WLNN:FBLock<ch>:DATA:SYMBols..... | 91 |
| [SOURce<hw>]:BB:WLNN:FBLock<ch>:DELeTe..... | 59 |
| [SOURce<hw>]:BB:WLNN:FBLock<ch>:DELeTe..... | 91 |
| [SOURce<hw>]:BB:WLNN:FBLock<ch>:ESSTream..... | 91 |
| [SOURce<hw>]:BB:WLNN:FBLock<ch>:FCOunt..... | 92 |
| [SOURce<hw>]:BB:WLNN:FBLock<ch>:GUARd..... | 92 |
| [SOURce<hw>]:BB:WLNN:FBLock<ch>:ILEaver:STATe..... | 92 |
| [SOURce<hw>]:BB:WLNN:FBLock<ch>:INSert..... | 92 |
| [SOURce<hw>]:BB:WLNN:FBLock<ch>:ITIME..... | 93 |
| [SOURce<hw>]:BB:WLNN:FBLock<ch>:MAC:ADDRess<st>..... | 93 |
| [SOURce<hw>]:BB:WLNN:FBLock<ch>:MAC:ADDRess<st>:STATe..... | 93 |
| [SOURce<hw>]:BB:WLNN:FBLock<ch>:MAC:DID..... | 94 |
| [SOURce<hw>]:BB:WLNN:FBLock<ch>:MAC:FCONtrol..... | 94 |
| [SOURce<hw>]:BB:WLNN:FBLock<ch>:MAC:FCONtrol:FDS..... | 94 |

| | |
|---|-----|
| [SOURce<hw>]:BB:WLNN:FBLOCK<ch>:MAC:FCONTROL:MDATA..... | 94 |
| [SOURce<hw>]:BB:WLNN:FBLOCK<ch>:MAC:FCONTROL:MFRAGMENTS..... | 94 |
| [SOURce<hw>]:BB:WLNN:FBLOCK<ch>:MAC:FCONTROL:ORDER..... | 94 |
| [SOURce<hw>]:BB:WLNN:FBLOCK<ch>:MAC:FCONTROL:PMANAGEMENT..... | 95 |
| [SOURce<hw>]:BB:WLNN:FBLOCK<ch>:MAC:FCONTROL:PVERSION..... | 95 |
| [SOURce<hw>]:BB:WLNN:FBLOCK<ch>:MAC:FCONTROL:RETRY..... | 95 |
| [SOURce<hw>]:BB:WLNN:FBLOCK<ch>:MAC:FCONTROL:SUBTYPE..... | 95 |
| [SOURce<hw>]:BB:WLNN:FBLOCK<ch>:MAC:FCONTROL:TDS..... | 95 |
| [SOURce<hw>]:BB:WLNN:FBLOCK<ch>:MAC:FCONTROL:TYPE..... | 95 |
| [SOURce<hw>]:BB:WLNN:FBLOCK<ch>:MAC:FCONTROL:WEP..... | 95 |
| [SOURce<hw>]:BB:WLNN:FBLOCK<ch>:MAC:FCS:STATE..... | 95 |
| [SOURce<hw>]:BB:WLNN:FBLOCK<ch>:MAC:HTCONTROL..... | 96 |
| [SOURce<hw>]:BB:WLNN:FBLOCK<ch>:MAC:HTCONTROL:ACCONSTRAINT..... | 96 |
| [SOURce<hw>]:BB:WLNN:FBLOCK<ch>:MAC:HTCONTROL:CALIBRATION:POSITION..... | 96 |
| [SOURce<hw>]:BB:WLNN:FBLOCK<ch>:MAC:HTCONTROL:CALIBRATION:SEQUENCE..... | 97 |
| [SOURce<hw>]:BB:WLNN:FBLOCK<ch>:MAC:HTCONTROL:CSISTEERING..... | 97 |
| [SOURce<hw>]:BB:WLNN:FBLOCK<ch>:MAC:HTCONTROL:FREQUEST..... | 97 |
| [SOURce<hw>]:BB:WLNN:FBLOCK<ch>:MAC:HTCONTROL:LACONTROL..... | 98 |
| [SOURce<hw>]:BB:WLNN:FBLOCK<ch>:MAC:HTCONTROL:RDGMORE..... | 98 |
| [SOURce<hw>]:BB:WLNN:FBLOCK<ch>:MAC:HTCONTROL:RESERVED..... | 99 |
| [SOURce<hw>]:BB:WLNN:FBLOCK<ch>:MAC:HTCONTROL:STATE..... | 99 |
| [SOURce<hw>]:BB:WLNN:FBLOCK<ch>:MAC:HTCONTROL:ZLF..... | 99 |
| [SOURce<hw>]:BB:WLNN:FBLOCK<ch>:MAC:QSCONTROL..... | 99 |
| [SOURce<hw>]:BB:WLNN:FBLOCK<ch>:MAC:QSCONTROL:STATE..... | 100 |
| [SOURce<hw>]:BB:WLNN:FBLOCK<ch>:MAC:SCONTROL:FRAGMENT:INCREMENT..... | 100 |
| [SOURce<hw>]:BB:WLNN:FBLOCK<ch>:MAC:SCONTROL:FRAGMENT:START..... | 100 |
| [SOURce<hw>]:BB:WLNN:FBLOCK<ch>:MAC:SCONTROL:SEQUENCE:INCREMENT..... | 101 |
| [SOURce<hw>]:BB:WLNN:FBLOCK<ch>:MAC:SCONTROL:SEQUENCE:START..... | 101 |
| [SOURce<hw>]:BB:WLNN:FBLOCK<ch>:MAC:SCONTROL:STATE..... | 101 |
| [SOURce<hw>]:BB:WLNN:FBLOCK<ch>:MAC:STATE..... | 101 |
| [SOURce<hw>]:BB:WLNN:FBLOCK<ch>:MODULATION<st>..... | 102 |
| [SOURce<hw>]:BB:WLNN:FBLOCK<ch>:PASTE..... | 59 |
| [SOURce<hw>]:BB:WLNN:FBLOCK<ch>:PASTE..... | 102 |
| [SOURce<hw>]:BB:WLNN:FBLOCK<ch>:PLCP:FORMAT..... | 102 |
| [SOURce<hw>]:BB:WLNN:FBLOCK<ch>:PLCP:LCBIT:STATE..... | 102 |
| [SOURce<hw>]:BB:WLNN:FBLOCK<ch>:PMODE..... | 103 |
| [SOURce<hw>]:BB:WLNN:FBLOCK<ch>:PREAMBLE:STATE..... | 103 |
| [SOURce<hw>]:BB:WLNN:FBLOCK<ch>:PSDU:BRATE..... | 103 |
| [SOURce<hw>]:BB:WLNN:FBLOCK<ch>:PSDU:BSPREADING:STATE..... | 104 |
| [SOURce<hw>]:BB:WLNN:FBLOCK<ch>:SCRAMBLER:MODE..... | 104 |
| [SOURce<hw>]:BB:WLNN:FBLOCK<ch>:SCRAMBLER:PATTERN..... | 105 |
| [SOURce<hw>]:BB:WLNN:FBLOCK<ch>:SERVICE:PATTERN..... | 105 |
| [SOURce<hw>]:BB:WLNN:FBLOCK<ch>:SMAPPING:BSELECTION..... | 106 |
| [SOURce<hw>]:BB:WLNN:FBLOCK<ch>:SMAPPING:INDEX..... | 106 |
| [SOURce<hw>]:BB:WLNN:FBLOCK<ch>:SMAPPING:MODE..... | 106 |
| [SOURce<hw>]:BB:WLNN:FBLOCK<ch>:SMAPPING:ROW<st>:COL<dir>:I..... | 107 |
| [SOURce<hw>]:BB:WLNN:FBLOCK<ch>:SMAPPING:ROW<st>:COL<dir>:Q..... | 108 |
| [SOURce<hw>]:BB:WLNN:FBLOCK<ch>:SMAPPING:TSHIFT<st>..... | 108 |
| [SOURce<hw>]:BB:WLNN:FBLOCK<ch>:SSTREAM..... | 108 |
| [SOURce<hw>]:BB:WLNN:FBLOCK<ch>:STATE..... | 109 |

| | |
|---|-----|
| [SOURce<hw>]:BB:WLNN:FBLOCK<ch>:STBC:STATe..... | 109 |
| [SOURce<hw>]:BB:WLNN:FBLOCK<ch>:STStream..... | 109 |
| [SOURce<hw>]:BB:WLNN:FBLOCK<ch>:TDWindowing:STATe..... | 110 |
| [SOURce<hw>]:BB:WLNN:FBLOCK<ch>:TMODe..... | 110 |
| [SOURce<hw>]:BB:WLNN:FBLOCK<ch>:TTIME..... | 110 |
| [SOURce<hw>]:BB:WLNN:FBLOCK<ch>:TYPE..... | 110 |
| [SOURce<hw>]:BB:WLNN:FILTer:ILENgtH..... | 65 |
| [SOURce<hw>]:BB:WLNN:FILTer:ILENgtH:AUTO..... | 65 |
| [SOURce<hw>]:BB:WLNN:FILTer:OSAMpling..... | 66 |
| [SOURce<hw>]:BB:WLNN:FILTer:OSAMpling:AUTO..... | 66 |
| [SOURce<hw>]:BB:WLNN:FILTer:PARAmeter:APCO25..... | 66 |
| [SOURce<hw>]:BB:WLNN:FILTer:PARAmeter:COsine..... | 66 |
| [SOURce<hw>]:BB:WLNN:FILTer:PARAmeter:COsine:COFS..... | 67 |
| [SOURce<hw>]:BB:WLNN:FILTer:PARAmeter:GAUSSs..... | 67 |
| [SOURce<hw>]:BB:WLNN:FILTer:PARAmeter:LPASSs..... | 67 |
| [SOURce<hw>]:BB:WLNN:FILTer:PARAmeter:LPASSEVM..... | 67 |
| [SOURce<hw>]:BB:WLNN:FILTer:PARAmeter:PGAuss..... | 68 |
| [SOURce<hw>]:BB:WLNN:FILTer:PARAmeter:RCOsine..... | 68 |
| [SOURce<hw>]:BB:WLNN:FILTer:PARAmeter:SPHase..... | 68 |
| [SOURce<hw>]:BB:WLNN:FILTer:TYPE..... | 65 |
| [SOURce<hw>]:BB:WLNN:IFBLOck..... | 58 |
| [SOURce<hw>]:BB:WLNN:IFBLOck..... | 58 |
| [SOURce<hw>]:BB:WLNN:PATH:COUPling[:STATe]..... | 60 |
| [SOURce<hw>]:BB:WLNN:PFBLOck..... | 59 |
| [SOURce<hw>]:BB:WLNN:PRESet..... | 60 |
| [SOURce<hw>]:BB:WLNN:PSDU:MODulation..... | 60 |
| [SOURce<hw>]:BB:WLNN:SETTing:CATalog..... | 61 |
| [SOURce<hw>]:BB:WLNN:SETTing:DELeTe..... | 61 |
| [SOURce<hw>]:BB:WLNN:SETTing:LOAD..... | 62 |
| [SOURce<hw>]:BB:WLNN:SETTing:STORE..... | 62 |
| [SOURce<hw>]:BB:WLNN:SRATe:VARiation..... | 69 |
| [SOURce<hw>]:BB:WLNN:STATe..... | 62 |
| [SOURce<hw>]:BB:WLNN:TRIGger:ARM:EXECute..... | 69 |
| [SOURce<hw>]:BB:WLNN:TRIGger:EXECute..... | 70 |
| [SOURce<hw>]:BB:WLNN:TRIGger:EXTErnal:SYNChronize:OUTPut..... | 70 |
| [SOURce<hw>]:BB:WLNN:TRIGger:OBASeband:DELAy..... | 71 |
| [SOURce<hw>]:BB:WLNN:TRIGger:OBASeband:INHibit..... | 71 |
| [SOURce<hw>]:BB:WLNN:TRIGger:OUTPut:DELAy:FIXed..... | 76 |
| [SOURce<hw>]:BB:WLNN:TRIGger:OUTPut<ch>:DELAy..... | 76 |
| [SOURce<hw>]:BB:WLNN:TRIGger:OUTPut<ch>:DELAy:MAXimum..... | 77 |
| [SOURce<hw>]:BB:WLNN:TRIGger:OUTPut<ch>:DELAy:MINimum..... | 77 |
| [SOURce<hw>]:BB:WLNN:TRIGger:OUTPut<ch>:FBINdex..... | 79 |
| [SOURce<hw>]:BB:WLNN:TRIGger:OUTPut<ch>:FINDeX..... | 79 |
| [SOURce<hw>]:BB:WLNN:TRIGger:OUTPut<ch>:MODE..... | 78 |
| [SOURce<hw>]:BB:WLNN:TRIGger:OUTPut<ch>:OFFTTime..... | 79 |
| [SOURce<hw>]:BB:WLNN:TRIGger:OUTPut<ch>:ONTTime..... | 78 |
| [SOURce<hw>]:BB:WLNN:TRIGger:OUTPut<ch>:PATTern..... | 80 |
| [SOURce<hw>]:BB:WLNN:TRIGger:OUTPut<ch>:PULSe:DIVider..... | 80 |
| [SOURce<hw>]:BB:WLNN:TRIGger:OUTPut<ch>:PULSe:FREQuency..... | 80 |
| [SOURce<hw>]:BB:WLNN:TRIGger:RMODE..... | 72 |

| | |
|--|----|
| [SOURce<hw>]:BB:WLNN:TRIGger:SLENgth..... | 72 |
| [SOURce<hw>]:BB:WLNN:TRIGger:SLUNit..... | 73 |
| [SOURce<hw>]:BB:WLNN:TRIGger:SOURce..... | 73 |
| [SOURce<hw>]:BB:WLNN:TRIGger[:EXTernal<ch>]:DELay..... | 74 |
| [SOURce<hw>]:BB:WLNN:TRIGger[:EXTernal<ch>]:INHibit..... | 74 |
| [SOURce<hw>]:BB:WLNN:VERSion..... | 63 |
| [SOURce<hw>]:BB:WLNN:WAVEform:CREate..... | 63 |
| [SOURce<hw>]:BB:WLNN[:TRIGger]:SEQuence..... | 75 |

Index

A

| | |
|----------------------------|----|
| ACC Constraint | 96 |
| AC Constraint | 39 |
| Addresses | 35 |
| Address State | 93 |
| Antenna Mode | 85 |
| Antennas | 23 |
| ARB Settings | 22 |
| Arm | 49 |
| Armed_Auto | 75 |
| Armed_Retrigger | 75 |
| Arm Trigger – WLAN-N | 69 |
| Auto | 75 |

B

| | |
|-----------------------|--------|
| Baseband filter | 44, 65 |
| BxT | 44 |
| B x T | 66 |

C

| | |
|---|--------|
| Calibration Position | 40 |
| Calibration PositionN | 96 |
| Calibration Sequence | 40, 97 |
| Channel Coding | 31 |
| Chip clock | 55 |
| Chip Clock Multiplier | 55 |
| Clipping Level | 45, 64 |
| Clipping Mode | 46, 64 |
| Clipping Settings | 22 |
| Clock Mode | 55, 81 |
| Clock parameters | 22 |
| Clock Source | 55, 82 |
| Coding Rate | 33 |
| Coupling Basebands | 21, 60 |
| Crest factor - Clipping | 64 |
| Crest factor – Clipping | 45, 64 |
| CSI Steering | 39, 97 |
| Current Range without Recalculation | 53, 77 |
| Cut Off Frequency Factor | 44 |
| Cut Off Frequency Shift | 44 |

D

| | |
|---|--------|
| Data Bits Per Second | 30 |
| Data List Management | 20 |
| Data Rate | 26, 32 |
| Default settings | 18, 60 |
| Delay | |
| Marker | 53 |
| Delay - Marker | 76 |
| Delay - Trigger | 74 |
| Delete IEEE 802.11n WLAN-N settings | 19, 61 |
| Disable Barker Spreading (CCK,PBCC) | 30 |
| Documentation Overview | 5 |
| Duration Id | 94 |

E

| | |
|-----------------------|--------|
| Edit Data List | 20 |
| Encoders | 32 |
| Execute Trigger | 49, 70 |

| | |
|--------------------------------|----|
| Extended Spatial | 29 |
| External Trigger Delay | 74 |
| External Trigger Inhibit | 74 |

F

| | |
|---|------------|
| FCS | 38 |
| FCS (checksum) | 35, 95 |
| Feedback Request | 40, 97 |
| Filtering Settings | 22 |
| Filter Parameter | 44, 66 |
| Filter Type | 44, 65 |
| Fixed Marker Delay Maximum | 77 |
| Fix marker delay to current range | 54, 76 |
| Frame Block Configuration | |
| Append | 27 |
| Boost | 26 |
| Copy | 27 |
| Data | 26 |
| Delete | 27 |
| DList/Pattern | 26 |
| Frames | 26 |
| Insert | 27 |
| Paste | 27 |
| Physical Mode | 25 |
| PPDU | 26 |
| State | 27 |
| Tx Mode | 25 |
| Type | 24 |
| Frame Block Configuration - Append | 58 |
| Frame Block Configuration - Copy | 59 |
| Frame Block Configuration - Data | 89 |
| Frame Block Configuration - Data List | 90 |
| Frame Block Configuration - Delete | 59 |
| Frame Block Configuration - Frames | 92 |
| Frame Block Configuration - Idle Time | 93 |
| Frame Block Configuration - Insert | 92 |
| Frame Block Configuration - Paste | 59 |
| Frame Block Configuration -Pattern | 90 |
| Frame Block Configuration - Physical Mode | 103 |
| Frame Block Configuration - State | 109 |
| Frame Block Configuration - Tx Mode | 110 |
| Frame Block Configuration - Type | 110 |
| Frame Block Index | 79 |
| Frame Body | 38 |
| Frame Control | 35, 94, 95 |
| Frame Index | 79 |

G

| | |
|-------------------------------------|----|
| Generate Waveform File | 20 |
| Global Trigger/Clock Settings | 56 |
| Guard | 32 |

H

| | |
|------------------------|--------|
| HT Config | 38 |
| HT Control | 42 |
| HT Control State | 96, 99 |

I

| | |
|-----------------|----|
| Idle Time | 26 |
| Imaginary | 24 |

Impulse Length 44, 65
 Impulse Length Auto State 65
 Increment every 37, 100, 101
 Interleaver Active 32

L

Link Adaption Control 40, 98
 Load IEEE 802.11n WLAN-N settings 19, 62

M

Magnitude 24
 Manual Trigger 49, 70
 Mapping Coordinates 23, 85
 Marker Delay 53, 76
 Marker Mode 51, 78
 Measured External Clock 55
 Multiplier 55, 82

N

Number Of Data Symbols 32
 Nyquist filter 44, 65

O

ON/OFF Ratio Marker 51, 79
 Output 23
 Oversampling 45, 66
 Oversampling Auto State 66

P

Phase 24
 PLCP P+H Format (CCK,PBCC) 33, 102
 PPDU Configuration - Channel Coding 88
 PPDU Configuration - Coding Rate 88
 PPDU Configuration - Data Bits Per Symbol 89
 PPDU Configuration -Data Length 90
 PPDU Configuration -Data Rate 91
 PPDU Configuration - Encoders 88
 PPDU Configuration - Extended Spatial Streams 91
 PPDU Configuration - Guard 92
 PPDU Configuration - Interleaver Active 92
 PPDU Configuration -Number of Data Symbols 91
 PPDU Configuration - Preamble/Header Active 103
 PPDU Configuration - Scrambler 104
 PPDU Configuration - Scrambler Init 105
 PPDU Configuration - Service Field 105
 PPDU Configuration - Space Time Block Coding 109
 PPDU Configuration - Space Time Streams 109
 PPDU Configuration - Spatial Streams 108
 PPDU Configuration - Stream 102
 PPDU Configuration - Time Domain Windowing Active . 110
 PPDU Configuration - Transition Time 110
 Preamble/Header 31
 PSDU Bit Rate 103
 PSDU Bit Rate (CCK,PBCC) 29
 PSDU Modulation 60
 PSDU Spreading 104
 Pulse Divider Marker 51, 80
 Pulse Frequency Marker 51, 80

Q

QoS Control 38, 99
 QoS Control State 100

R

RDG/More PPDU 39, 98
 Real 24
 Recall IEEE 802.11n WLAN-N settings 19, 62
 Reserved 39, 99
 Retrigger 75
 Roll Off 44, 66
 Running 48
 Running - Trigger 72

S

Sample Clock Multiplier 82
 Sample Rate Variation 44
 Save-Recall 19, 61
 Save IEEE 802.11n WLAN-N settings 19, 62
 Scrambler 31
 Scrambler Init 32
 Sequence Control 36, 101
 Sequence Length - Trigger 72
 Service Field 33
 Service Field Clock Bits (CCK,PBCC) 33, 102
 Set Synchronization Settings 54
 Set Synchronization Settings – WLAN-N 83
 Set to default 18, 60
 Signal Duration 48
 Signal Duration Unit 48
 Signal Duration Unit - Trigger 73
 Single Duration Unit - Trigger 72
 Space Time Block Coding 29
 Space Time Streams 29
 Spatial Mapping Beamforming File Selection 106
 Spatial Mapping I-Value 107
 Spatial Mapping Index k 106
 Spatial Mapping Mode 42, 106
 Spatial Mapping Q-Value 108
 Spatial Mapping Time Shift 108
 Spatial Streams 29
 Standard settings 18, 60
 Start Number 37, 100, 101
 State 17, 62
 Clipping 45
 State - Clipping 64
 Stopped 48
 Stream 29
 Sync. Output to External Trigger 49
 Synchronization mode 54
 Synchronization Mode – WLAN-N 83

T

Time Domain Windowing Active 32
 Time Shift 42
 Time Shift Element I 43
 Time Shift Element Q 43
 Transition Time 33
 Transmission Bandwidth 58
 Transmission Chain Mapping - Imaginary 87
 Transmission Chain Mapping - Output File Select 86
 Transmission Chain Mapping - Real 87
 Transmission Chain Mapping - Real - Output 86
 Trigger Delay 51
 Trigger Delay External 74
 Trigger Delay Other Baseband 71
 Trigger Inhibit 51
 Trigger Inhibit External 74

| | |
|--------------------------------------|--------|
| Trigger Inhibit Other Baseband | 71 |
| Trigger Mode | 75 |
| Armed | 48 |
| Auto | 48 |
| Retrigger | 48 |
| Single | 48 |
| Trigger parameters | 22 |
| Trigger Source | 49, 73 |

U

| | |
|--------------------------------------|----|
| User Marker / AUX I/O Settings | 56 |
|--------------------------------------|----|

V

| | |
|---------------|----|
| Version | 63 |
|---------------|----|

W

| | |
|----------------------|----|
| Waveform File | 20 |
| WLAN-N Version | 63 |

Z

| | |
|------------------------|--------|
| ZLF Announcement | 39, 99 |
|------------------------|--------|